

CHAPTER 16
SUBDIVISION ORDINANCE

[Adopted eff. 6/9/68, under R. S. 1964, T. 30, Sec. 4956] (With revisions eff. 7/13/93 and subsequent revisions eff. 2/12/94 , 7/13/94, 1/10/96 and 12/10/03)]

| | | | |
|----|---------------------|---|----|
| 6 | Article I. | Purpose, Authority, Scope, Definitions | 1 |
| 7 | Sec. 16-1-1. | Purpose | 1 |
| 8 | Sec. 16-1-2. | Authority | 3 |
| 9 | Sec. 16-1-3. | Scope | 3 |
| 10 | Sec. 16-1-4. | Definitions | 3 |
| 11 | | | |
| 12 | Article II. | Review Procedures | 6 |
| 13 | Sec. 16-2-1. | General Procedures | 6 |
| 14 | Sec. 16-2-2. | Pre-Application Process | 6 |
| 15 | Sec. 16-2-3. | Review & Approval of Minor Subdivision Plans | 6 |
| 16 | Sec. 16-2-4. | Review & Approval of Major Subdivision Plans | 8 |
| 17 | Sec. 16-2-5. | Amendments to Previously Approved | |
| 18 | | Subdivision Plans | 14 |
| 19 | Sec. 16-2-6. | Inspection of Required Improvements | 14 |
| 20 | | | |
| 21 | Article III. | Standards | 16 |
| 22 | Sec. 16-3-1. | General Standards of Subdivision Design | 16 |
| 23 | Sec. 16-3-2. | Road Design & Construction Design | 20 |
| 24 | | Road Classification Standards Table | |
| 25 | Sec. 16-3-3. | Design of Other Improvements | 35 |
| 26 | Sec. 16-3-4. | Additional Standards | 36 |
| 27 | Sec. 16-3-5. | Waivers | 36 |
| 28 | Sec. 16-3-6 | Legal Provisions | 36 |
| 29 | | | |
| 30 | Appendix A. | Minor Subdivision Submission list | 37 |
| 31 | Appendix B. | Major Subdivision Submission list | 40 |
| 32 | Appendix C. | Road Tree List | 44 |
| 33 | Appendix D. | Turnaround designs | |
| 34 | Appendix E. | Road design profiles | |

ARTICLE I. Purpose, Authority, Scope, Definitions.

Sec. 16-1-1. Purpose. This Ordinance is designed to promote the health, safety, convenience and general welfare of the Inhabitants of the Town of Cape Elizabeth by encouraging and ensuring sound planning, the use of the environment under healthful conditions, the imaginative and orderly use of land, compliance with the goals and objectives of the Comprehensive Plan, and development that fits harmoniously into the existing natural environment and rural character.

Sec. 16-1-2. Authority. This Ordinance shall apply to all land within the limits of the Town of Cape Elizabeth, Cumberland County, Maine and shall be administered by the

1 Planning Board of the Town of Cape Elizabeth, hereinafter called “the Planning Board”,
2 and the Town’s designated staff.

3 **Sec. 16-1-3 Scope.**

4
5 (a) Any person, firm, corporation or other legal entity proposing to sell, lease or
6 convey, or to offer or agree to sell, lease or convey, any land in a subdivision any
7 portion of which is within the limits of the Town of Cape Elizabeth, shall first
8 submit such subdivision for approval by the Planning Board in accordance with
9 this Ordinance and shall record in the Cumberland County Registry of Deeds a
10 plan thereof bearing the approval of the Planning Board.

11
12 (b) No utility installations; no ditching, grading or construction of roads; no grading
13 of land or lots; and no construction of buildings shall be done on any part of the
14 proposed subdivision until a subdivision application has been submitted, reviewed
15 and finally approved as provided by this Ordinance.

16
17 **Sec. 16-1-4 Definitions.**

18
19 In general, words and terms used in this Ordinance shall have their customary dictionary
20 meanings, but the following words and terms as used in this Ordinance are defined as
21 follows:

22 “**Applicant**” - the record owner, or a person having an interest in the land either through
23 written option or contract.

24 “**Access Road**” - any road which includes (1) an eighteen (18) feet wide traveled way,
25 (2) deeded and actual rights of public emergency access, and (3) year-round maintenance,
26 including snow plowing of the road, the responsibility of which is documented in a
27 binding written agreement if the road is not located within a public right-of-way.

28 “**Arterial**” - a road which is a major link with other communities. This road typically
29 averages in excess of three thousand (3,000) trips per day with an average length of each
30 trip of more than one mile. Arterials accommodate residential, agricultural and most of
31 the Town’s commercial development. Direct access by residential development should be
32 discouraged, and commercial access should be combined with adjacent commercial uses
33 where feasible.

34 “**AASHTO**” - The American Association of State Highway and Transportation Officials,
35 an organization that establishes transportation specifications.

36 “**Building Envelope**” - The area within a lot where the main and accessory buildings
37 shall be located.

38 “**Cluster Development**” - A type of subdivision development for single family detached
39 dwellings, multiplex dwellings, or a combination of both, where lot sizes, lot widths, and
40 building setbacks are reduced below the minimum requirements of this ordinance and the
41 land gained thereby is set aside as open space.

1 **“Collector”** - a road that collects traffic from the most densely settled areas and
2 typically connects to an adjacent community. This road averages in excess of 2,000 trips
3 per day with an average length of each trip over more than one mile. Collectors are
4 located in areas with a dense, suburban pattern of development. The design of collectors
5 must provide heavy traffic flow capacity and protect sensitive scenic areas and
6 neighborhoods. Direct access by single driveway should be discouraged.

7 **“Dead-end road”** - a road with a single, common means of ingress and egress.
8 [Rev. eff. 7/13/94]

9
10 **“Ditch”** - a channel for conveying surface water outside the traveled way.

11
12 **“Dwelling unit”** - any part of a structure which, through sale or lease, is intended for
13 human habitation, including single-family and multi-family housing, condominiums,
14 apartments and time-share units.

15
16 **“Easement”**- a grant of one or more of the property rights by the property owner to
17 and/or for use by the public, a corporation, or another person or entity. Examples of
18 easements include but are not limited to drainage, conservation, emergency access,
19 pedestrian, utility, road and open space easements.

20
21 **“Emergency Access Lane”**- a public or private paved road with a minimum width of
22 eighteen (18) feet which is not open to through vehicular traffic. This type of road may
23 provide secondary emergency access to an area served by a dead-end road. [Rev. eff.
24 6/12/91]

25
26 **“Esplanade”** - a landscaped strip of land located between a road and a sidewalk or
27 between two roads.

28 **“Farmland”** - a parcel consisting of five (5) or more acres of land that is (1) classified as
29 prime farmland, unique farmland or farmland of statewide or local importance by the
30 Natural Resources Conservation Service within the United States Department of
31 Agriculture; or (2) used for the production of agricultural products as defined in Title 7
32 M.R.S.A. Sec. 152, subsection 2.

33 **“Feeder”** - a road that connects local roads to other roads. This road is typically densely
34 developed and serves more than one-hundred (100) dwellings or approximately one-
35 thousand (1,000) trips per day. Feeders primarily serve residential traffic where access by
36 single driveway is common.

37 **“Local Road”** - a road that provides direct access to adjacent residential land or the
38 Town center area. The local road is the most common road classification and carries a
39 low volume of trips in residential areas, although higher volumes are also common in the
40 Town center area. Local roads should be designed for slow speeds and frequent
41 pedestrian travel.

42 **“Lot”** - an area of land in one ownership, regardless of the dates or sources of acquisition
43 thereof and regardless of the buildings and uses existing thereon, having definite
44 boundaries by recorded plan or deed and having an area of less than forty (40) acres.

1 **“Manufactured Housing Unit”** - structures, transportable in one or more sections,
2 which were constructed in a manufacturing facility and are transported to a building site
3 and designed to be used as dwellings when connected to the required utilities, including
4 the plumbing, heating, air conditioning and electrical systems contained therein.

5 **“Manufactured Housing Park”** - a parcel of land under unified ownership designed
6 and/or used to accommodate three or more manufactured housing units.

7 **“Manufactured Housing Park Lot”** - the area of land on which an individual home is
8 situated within a manufactured housing park and which is reserved for use by the
9 occupants of that home.

10 **“MDOT”** - The State of Maine Department of Transportation.

11 **“M.R.S.A”** - Maine Revised Statutes Annotated.

12 **“MUTCD”** - The Manual on Uniform Traffic Control Device Standards.

13 **“Multiplex Housing”** - attached dwelling units, as defined in the Zoning Ordinance
14 (Chapter 19).

15 **“Performance Guarantee”** - any security that may be accepted by the Town to assure
16 that improvements required as part of an application for development will be completed
17 in compliance with the approved plans.

18 **“Planner”** - that person designated by the Town to assist the Planning Board in its
19 subdivision and site plan review.

20 **“Planning Board Decision”** - the Planning Board vote to approve or conditionally
21 approve the preliminary or final plan.

22 **“Principal Structure”** - any building other than one that is used for purposes wholly
23 incidental or accessory to the use of another building on the same premises.

24 **“Private Road”** - a road or way that provides access to more than one principal structure
25 and which is not owned by the Town.

26 **“Resubdivision”** - the replatting of all or part of the land included in a subdivision plan
27 already approved by the Planning Board.

28 **“Right-of-way”**- (1) a strip of land acquired by conveyance, reservation, dedication,
29 forced dedication, prescription or condemnation and intended to be occupied by a road,
30 sidewalk, crosswalk, railroad, electric transmission lines, oil or gas pipeline, water line,
31 sanitary storm sewer, or other similar uses; (2) generally, the right of one to pass over the
32 property of another.

33 **“Road”** - a public or private way for vehicular traffic however designated, serving more
34 than one residential unit or more than one lot.

35 **“Rural Connector”** - A road that handles trips between different parts of Town and
36 connects rural residential development to arterials. This road typically carries less than
37 1,000 trips per day with an average length of more than one (1) mile. Rural connectors
38 are located in primarily rural residential areas and the rural character should be
39 maintained. Access by residential development should preferably be by a local road, but
40 may be from a single driveway.

1 **“Sight Distance”** - See Section 16-3-2 (a) (1) of this Ordinance.

2 **“Site Improvement”** - all changes and construction required of a subdivision to be in
3 compliance with Planning Board approval and Town Standards.

4 **“Spaghetti lot”** - Any lot in a proposed subdivision with shore frontage on a river,
5 stream, brook, great pond, or coastal wetland, as these features are defined in Title 38,
6 section 480-B, with a lot depth to shore frontage ratio greater than 5 (five) to 1 (one).

7 **“Standard Boundary Survey”** - A map of a quantity of real estate prepared by a
8 professional land surveyor registered in the State of Maine and based on (1) adequate
9 research to support a professional opinion of boundary location, (2) field work including
10 an inspection of the real estate and (3) the preparation of a plan, drawn to scale and
11 including property boundary lines, easements and rights-of-way and existing structures,
12 suitable for recording.

13

14 **“Structure”** - Anything constructed or erected with a fixed location on or in the ground,
15 or attached to something having a fixed location on or in the ground, including, but not
16 limited to, buildings, mobile homes, retaining walls, billboards, signs, piers and floats. It
17 does not include a wharf, fish weir or trap that may be licensed under Title 38, chapter 9.
18 A new structure or structures includes any structures for which construction begins on or
19 after September 23, 1988. The area included in the expansion of an existing structure is
20 deemed to be a new structure for the purposes of the Subdivision Ordinance.

21 **“Subdivision”** - the division of a tract or parcel of land into three (3) or more lots within
22 any five (5) year period, which period begins after September 22, 1971, whether
23 accomplished by sale, lease, development, buildings or otherwise. The term
24 “subdivision” also includes the division of a new structure or structures on a tract or
25 parcel of land into three (3) or more dwelling units within a five (5) year period, the
26 construction or placement of three (3) or more dwelling units on a single tract or parcel of
27 and the division of an existing structure or structures previously used for commercial or
28 industrial use into three (3) or more dwelling units within a five (5) year period.

29 A. In determining whether a tract or parcel of land is divided into three (3) or more
30 lots, the first dividing of such tract or parcel is considered to create the first two
31 (2) lots and the next dividing of either of said first two lots, by whomever
32 accomplished, is considered to create a third lot, unless:

33 (1) Both dividings are accomplished by a subdivider who has retained one of the
34 lots for the subdivider’s own use as a single family residence for a period of at
35 least five (5) years immediately preceding the second division: or

36 (2) The division of the tract or parcel is otherwise exempt under subsection D
37 below.

38 B. The dividing of a tract or parcel of land and the lot or lots so made, which
39 dividing or lots when made are not subject to the Subdivision Ordinance, do not
40 become subject to the Subdivision Ordinance by the subsequent dividing of that
41 tract or parcel of land or any portion of that tract or parcel of land. The municipal
42 reviewing authority shall consider the existence of the previously created lot or
43 lots in reviewing a proposed subdivision created by a subsequent dividing.

1 C. A lot of forty(40) or more acres shall not be counted as lots when the lot is located
2 entirely outside of the Shoreland Performance Overlay District.

3 D. Exceptions.

4 (1) A division accomplished by devise does not create a lot or lots for the
5 purposes of this definition, unless the intent of the transferor is to avoid the
6 objectives of the Subdivision Ordinance.

7 (2) A division accomplished by condemnation does not create a lot or lots for the
8 purposes of this definition, unless the intent of the transferor is to avoid the
9 objectives of the Subdivision Ordinance.

10 (3) A division accomplished by order of court does not create a lot or lots for the
11 purposes of this definition, unless the intent of the transferor is to avoid the
12 objectives of the Subdivision Ordinance.

13 (4) A division accomplished by gift to a person related to the donor of an interest
14 in property held by the donor for a continuous period of five (5) years prior to
15 the division by gift does not create a lot or lots for the purposes of this
16 definition, unless the intent of the transferor is to avoid the objectives of the
17 Subdivision Ordinance. If the real estate exempt under this definition is
18 transferred within five (5) years to another person not related to the donor of
19 the exempt real estate as provided in this paragraph, then the previously
20 exempt division creates a lot or lots for the purposes of the Subdivision
21 Ordinance. "Person related to the donor" means a spouse, parent, grandparent,
22 brother, sister, child or grandchild related by blood, marriage or adoption. A
23 gift under this definition can not be given for consideration that is more than
24 one-half (1/2) the assessed value of the real estate.

25 (5) A division accomplished by a gift to a municipality if that municipality
26 accepts the gift does not create a lot or lots for the purposes of this definition,
27 unless the intent of the transferor is to avoid the objectives of the Subdivision
28 Ordinance.

29 (6) A division accomplished by the transfer of any interest in land to the owners
30 of land abutting that land does not create a separate lot does not create a lot or
31 lots for the purposes of this definition, unless the intent of the transferor is to
32 avoid the objectives of the Subdivision Ordinance. If the real estate exempt
33 under this paragraph is transferred within five (5) years to another person
34 without all of the merged land, then the previously exempt division creates a
35 lot or lots for the purposes of the Subdivision Ordinance.

36 (7) The grant of a bona fide security interest in an entire lot that has been
37 exempted from the definition of subdivision under subsection D above, or
38 subsequent transfer of that entire lot by the original holder of the security
39 interest or that person's successor in interest, does not create a lot for the
40 purposes of this definition, unless the intent of the transferor is to avoid the
41 objectives of the Subdivision Ordinance.

- 1 E. The division of a tract or parcel of land into three (3) or more lots and upon each
2 of which lots permanent dwelling structures legally existed before September 23,
3 1971 is not a subdivision.
- 4 F. In determining the number of dwelling units in a structure, the provisions of the
5 Subdivision Ordinance regarding the determination of the number of lots apply,
6 including exemptions from the definition of a subdivision of land.
- 7 G. Notwithstanding the provisions of the Subdivision Ordinance, leased dwelling
8 units are not subject to subdivision review if the municipal reviewing authority
9 has determined that the units are otherwise subject to Site Plan Review under the
10 Zoning Ordinance.

11 **“Major Subdivision”** - A subdivision containing more than five (5) lots, or requiring
12 substantial extension of municipal facilities or any new public road, or falling under the
13 cluster provisions of the Zoning Ordinance, or multiplex housing as defined in the Zoning
14 Ordinance or a manufactured housing park herein.

15 **“Minor Subdivision”** - A subdivision containing not more than five (5) lots and is not
16 otherwise defined as a major subdivision.

17 **“Through road”** - a road with more than one means of ingress or egress. Both means of
18 ingress and egress must, at a minimum, meet the standards of an access road. [Rev. eff.
19 7/13/94]

20 **“Tract or parcel of land”**- Tract or parcel of land means all contiguous land in the same
21 ownership, except that lands located on opposite sides of a public or private road are
22 considered each a separate tract or parcel of land unless the road was established by the
23 owner of land on both sides of the road after September 22, 1971.

24 **“Town Engineer”**- that person designated by the Town to provide engineering advice to
25 the Planning Board in its subdivision and site plan review.

26 **“Traveled Way”** - that portion of a right-of-way which is regularly used for vehicular
27 traffic.

28 **Article II. Review Procedures**

29 **Sec. 16-2-1. General Procedures.** In all stages of the subdivision review process, the
30 burden of proof shall be upon the applicant proposing the subdivision.

31 **(a) Public Record.** The Planning Board shall maintain a permanent record of all its
32 meetings, proceedings and correspondence. The Planning Board shall specify in writing
33 its decisions and findings of fact.

34 **(b) Public Notice.** When notice to abutters is required, the Planner shall cause notice
35 to be given by mail to the owners, as currently listed by the Town Tax Assessor, of all
36 properties within 500’ of the proposed project property line boundary. If the project abuts
37 an adjacent municipality, the Planner shall notify the adjacent municipality’s planning
38 staff and request that all pertinent property owners be notified of the project proposal.
39 Such notice shall include the date, time and location of the meeting and the location and
40 general description of the proposed development.

1 If a public hearing is scheduled, mailed notice shall be provided as described above. In
2 addition, the Planner shall cause notice of the date, time and place of the hearing to be
3 published at least two (2) times in a newspaper having general circulation in the Town of
4 Cape Elizabeth. The date of the first publication must be at least seven (7) days before the
5 public hearing.

6 **(c) Review Escrow Account.** In addition to the application fees set by the Town
7 Council, a Review Escrow Fee to defray the Town's costs for application review by the
8 Town Engineer and/or other independent consulting services shall be provided. The fee
9 shall be recommended by the Town Engineer or consultant and approved by the Town
10 Manager upon initial review of the application and paid to the Town by the applicant
11 prior to the next meeting with the Planning Board. The fee shall be deposited in a Review
12 Escrow Account designated for that application. If the costs of application review by the
13 Town Engineer and/or other consulting services exceed the amount of the Review
14 Escrow Account, the applicant shall pay an additional fee to the Town that shall be
15 recommended by the Town Engineer or consultant and approved by the Town Manager
16 based upon the status of the application. Any balance in the account remaining after a
17 final decision on the application by the Planning Board and satisfaction of any approval
18 conditions shall be returned to the applicant unless there is an appeal or other legal action
19 pending with respect to the Planning Board's approval. All interest from the Review
20 Escrow Account shall accrue to the account and shall be applied toward the Town's cost
21 in reviewing the application.

22
23 **(d) Duration of Time.** Unless otherwise specified, number of days shall be
24 calculated as calendar days.

25
26 **Sec. 16-2-2. Pre-Application Process.** Prior to submitting an application for subdivision
27 review, the applicant shall meet with the Planning Board at a workshop at least once to
28 discuss the proposal generally, acquaint the Planning Board with the nature of the
29 proposal and the location, topography and other attributes of its site, review potential
30 submission waivers and obtain preliminary classification of the proposal as either a minor
31 or major subdivision. The Planner shall arrange for public notice of the meeting in
32 accordance with Sec. 16-2-1(b).

33 **Sec. 16-2-3. Review and Approval of Minor Subdivisions**

34 **(a) Procedures.**

35 1. **Formal Submission.** The subdivision applicant or an agent duly authorized in writing,
36 shall submit to the Planner a subdivision application for consideration by the Planning
37 Board together with the fee therefore as prescribed by the Town Council, and
38 fourteen (14) complete copies of the proposed subdivision plans and materials. All
39 plans and materials shall be submitted at least eighteen (18) days prior to the Planning
40 Board's next scheduled meeting. Prior to the first meeting with the Planning Board,
41 the applicant shall also establish a Review Escrow Account under the terms in Sec.
42 16-2-1(c).

43
44 2. **Preliminary Completeness.** Within thirty(30) days of the receipt of a subdivision
45 application and accompanying materials, the Planner, in consultation with the

1 Planning Board Chair, shall make a preliminary determination as to completeness. If
2 the application is preliminarily determined to be incomplete, the Planner shall so
3 notify the applicant in writing and shall list in the written determination the materials
4 that must be submitted in order to make the application complete. If an applicant fails
5 to submit a complete application within four (4) months of the date of the Planner's
6 preliminary written determination, the application shall be deemed withdrawn. When
7 the Planner makes the preliminary determination that an application is complete, the
8 application shall be scheduled for consideration at the next available Planning Board
9 meeting. Once scheduled, the Planner shall promptly notify the applicant of the time
10 and place of such meeting. No action taken by the Planner, either alone or in
11 consultation with the Planning Board Chair, with respect to reviewing a subdivision
12 application, shall result in an application being deemed pending for the purposes of
13 Title 1, M.R.S.A. Sec. 302. The Planner, either alone or in consultation with the
14 Planning Board Chair, shall have no authority to review the substance of a
15 subdivision application to determine whether it complies with the subdivision review
16 criteria.
17

- 18 3. Public Notice. The Planner shall arrange for public notice of the meeting in
19 accordance with Sec. 16-2-1 (b).
- 20 4. Planning Board Completeness. At its first meeting for consideration of an application
21 for approval of a subdivision, the Planning Board shall determine whether the
22 application is complete or incomplete. Within seven (7) days of the first regular
23 meeting, the Planning Board shall provide to the applicant a dated letter
24 acknowledging receipt of the application and the Planning Board's determination as
25 to completeness. If the application is determined to be incomplete, the Planning
26 Board shall list in its written determination the materials that must be submitted in
27 order to make the application complete. If an applicant fails to submit a complete
28 application within four (4) months of the Planning Board letter or within four (4)
29 months of the written determination of the Planner, the application shall be deemed
30 withdrawn, unless said time limitation is otherwise extended by the Planning Board
31 for good cause. When the application is deemed complete, the Planning Board shall
32 begin review of the proposed subdivision.
- 33 5. Site Walk. One or more site walks may be scheduled by the Planning Board. The
34 applicant shall provide temporary markers of key subdivision elements, such as but
35 not limited to road centerlines and wetland boundaries, on the site prior to the site
36 walk at the request of the Planning Board.
37
- 38 6. Public Hearing. The Planning Board, shall hold a public hearing on a minor
39 subdivision application within thirty (30) days of the date that the application is
40 determined to be complete. Public notice shall be provided in accordance with
41 Section 16-2-1(b) of this Chapter.
42

43 The Planning Board shall conduct the hearing as to assure full, but not repetitive,
44 public participation. The applicant shall be prepared to respond fully to questioning
45 by the public and the Planning Board. The Planning Board may, upon its own motion,

1 extend the hearing once for a period not exceeding thirty (30) days and to a date that
2 shall be announced.

3 7. Planning Board Decision. The Planning Board shall approve, or approve with
4 conditions, or disapprove the Subdivision Plan: (i) within sixty (60) days from the
5 date of the date that the application is determined to be complete, or (ii) within such
6 other time that may be mutually agreed upon by both the Planning Board and the
7 applicant.
8

9 **b) Submission Requirements.** Minor Subdivision Plan submissions shall conform
10 to the standards and requirements contained in Appendix A of this Ordinance.

11

12 **Sec. 16-2-4. Review and Approval of Major Subdivision Plans.**

13

14 **(a) Preliminary Plan Procedures.**

15 1. Formal Submission. The subdivision applicant, or an agent duly authorized in writing,
16 shall submit to the Planner a subdivision application for consideration by the Planning
17 Board together with the fee therefore as prescribed by the Town Council, and
18 fourteen (14) complete copies of the proposed preliminary subdivision plans and
19 materials. All plans and materials shall be submitted at least eighteen (18) calendar
20 days prior to the Planning Board's next scheduled meeting. Prior to the first meeting
21 with the Planning Board, the applicant shall also establish a Review Escrow Account
22 under the terms in Sec. 16-2-1(c).
23

24 2. Preliminary Completeness. Within thirty(30) days of the receipt of a preliminary
25 subdivision application and accompanying materials, the Planner, in consultation with
26 the Planning Board Chair, shall make a preliminary determination as to completeness.
27 If the application is preliminarily determined to be incomplete, the Planner shall so
28 notify the applicant in writing and shall list in the written determination the materials
29 that must be submitted in order to make the application complete. If an applicant fails
30 to submit a complete application within four (4) months of the date of the Planner's
31 preliminary determination, the application shall be deemed withdrawn. When the
32 Planner makes the preliminary determination that an application is complete, the
33 application shall be scheduled for consideration at the next available Planning Board
34 Meeting. Once scheduled, the Planner shall promptly notify the applicant of the time
35 and place of such meeting. No action taken by the Planner, either alone or in
36 consultation with the Planning Board Chair, with respect to reviewing a subdivision
37 application, shall result in an application being deemed pending for the purposes of
38 Title 1, M.R.S.A. Section 302. The Planner, either alone or in consultation with the
39 Planning Board Chair, shall have no authority to review the substance of a
40 subdivision application to determine whether it complies with the subdivision review
41 criteria.
42

43 3. Public Notice. The Planner shall arrange for public notice of the meeting in
44 accordance with Sec. 16-2-1(b).
45

1 4. Planning Board Completeness. At its first meeting for consideration of an application
2 for preliminary approval of a subdivision, the Planning Board shall determine
3 whether the application is complete or incomplete. Within seven (7) days of the first
4 regular meeting, the Planning Board shall provide to the applicant a dated letter
5 acknowledging receipt of the application and the Planning Board's determination of
6 completeness. If the application is determined to be incomplete, the Planning Board
7 shall list in its written determination the materials that must be submitted in order to
8 make the application complete. If an applicant fails to submit a complete application
9 within four (4) months of the Planning Board letter or within four (4) months of the
10 written determination of the Planner, the application shall be deemed withdrawn
11 unless said time limitation is otherwise extended by the Planning Board for good
12 cause. When the application is deemed complete, the Planning Board shall begin
13 review of the proposed subdivision.

14
15 6. Site Walk. One or more site walks may be scheduled by the Planning Board. The
16 applicant shall provide temporary markers of key subdivision elements, such as but
17 not limited to road centerlines and wetland boundaries, on the site prior to the site
18 walk at the request of the Planning Board.

19
20 7. Public Hearing. The Planning Board shall hold a public hearing on a major
21 subdivision application within thirty (30) days of the date that the preliminary
22 subdivision application is determined to be complete. Public notice shall be provided
23 in accordance with Sec. 16-2-1(b) of this Chapter.

24
25 The Planning Board shall conduct the hearing as to assure full, but not repetitive,
26 public participation. The applicant shall be prepared to respond fully to questioning
27 by the public and the Planning Board. The Planning Board may, upon its own motion,
28 extend the hearing once for a period not exceeding thirty (30) days and to a date that
29 shall be announced.

30 8. Planning Board Decision. The Planning Board shall approve, or approve with
31 conditions, or disapprove the Preliminary Plan: (i) within thirty (30) days after the
32 date of the public hearing, or (ii) within such other time that may be mutually agreed
33 upon by both the Planning Board and the applicant. Preliminary Plan approval shall
34 not constitute approval of the Final Plan, but rather shall be deemed an expression of
35 approval of the approach submitted on the Preliminary Plan as a guide to preparation
36 of the Final Plan.

37
38 **(b) Preliminary Plan Submission Requirements.**

39 Preliminary Plan submissions shall conform to the standards and requirements contained
40 in Appendix B of this Ordinance.

41 **(c) Final Plan Procedures.**

42 1. Formal Submission. Within six (6) months following the Planning Board's approval
43 or approval with conditions of an applicant's Preliminary Plan, the applicant shall file
44 with the Planner for Planning Board consideration, a Final Plan application for the
45 subdivision with fourteen (14) copies of the materials herein prescribed. If such

1 application is not filed within such period, the application shall be deemed withdrawn
2 and shall no longer be considered a pending subdivision application, unless said time
3 limitation is otherwise extended by the Planning Board for good cause.
4

5 2. Final Subdivision Plan Preliminary Completeness. Within thirty(30) days of the
6 receipt of a final subdivision application and accompanying materials, the Planner in
7 consultation with the Planning Board Chair, shall make a preliminary determination
8 of completeness. If the application is preliminarily determined to be incomplete, the
9 Planner shall so notify the applicant in writing and shall in the written determination
10 the materials that must be submitted in order to make the application complete. If an
11 applicant fails to submit a complete application within four (4) month of the date of
12 the Planner's preliminary written determination, the application shall be deemed
13 withdrawn. When the Planner makes the preliminary determination that an
14 application is complete, the application shall be scheduled for consideration at the
15 next available Planning Board meeting. Once scheduled, the Planner shall promptly
16 notify the applicant of the time and place of such meeting. No action taken by the
17 Planner, either alone or in consultation with the Planning Board Chair, with respect to
18 reviewing a subdivision application, shall result in an application being deemed
19 pending for the purposes of Title 1, M.R.S.A. Sec. 302. The Planner, either alone or
20 in consultation with the Planning Board Chair, shall have no authority to review the
21 substance of a subdivision application to determine whether it complies with the
22 subdivision review criteria.
23

24 3. Public Notice. Once a Planning Board meeting is scheduled, the Planner shall also
25 cause notice to be given per Sec. 16-2-1(b).
26

27 4. Planning Board Final Subdivision Plan Completeness. At its first meeting for
28 consideration of an application for final approval of a subdivision, the Planning Board
29 shall determine whether the application is complete or incomplete Within seven (7)
30 days of the first regular meeting, the Planning Board shall provide to the applicant a
31 dated letter acknowledging receipt of the application and the Planning Board's
32 determination of completeness. If the application is determined to be incomplete, the
33 Planning Board shall list in its written determination the materials that must be
34 submitted in order to make the application complete. If an applicant fails to submit a
35 complete application within four (4) months of the Planning Board letter or within
36 four (4) months of the written determination of the Planner, the application shall be
37 deemed withdrawn and shall no longer be considered a pending subdivision
38 application, unless said time limitations is otherwise extended by the Planning Board
39 for good cause. When the application is deemed complete, the Planning Board shall
40 begin review of the proposed subdivision.
41

42 5. Site walk. One or more site walks may be scheduled by the Planning Board. The
43 applicant shall provide temporary markers of key subdivision elements, such as but
44 not limited to road centerlines and wetland boundaries, on the site prior to the site
45 walk at the request of the Planning Board.
46

1 6. Public Hearing. The Planning Board may schedule a public hearing on the final
2 Subdivision plan if it considers any changes in the plan sufficient to warrant further
3 public comment. Public notice shall be given in accordance with Section 16-2-1 (b) of
4 this Ordinance.

5
6 If a public hearing is held, the Planning Board shall conduct the hearing as to assure
7 full, but not repetitive, public participation. The applicant shall be prepared to
8 respond fully to questioning by the public and the Planning Board. The Planning
9 Board may, upon its own motion, extend the hearing once for a period not exceeding
10 thirty (30) days and to a date which shall be announced.

11
12 7. Planning Board Decision. The Planning Board shall approve, or approve with
13 conditions or disapprove the Final Subdivision Plan: (i) within thirty (30) days of the
14 date of the public hearing; (ii) within sixty (60) days of the date that the application
15 was determined to be complete if no public hearing is held; or (iii) within such other
16 time that may be mutually agreed upon by both the Planning Board and the applicant.

17
18 **(d) Final Plan Submission Requirements.** Final Subdivision Plan submissions shall
19 conform to the standards and requirements contained in Appendix B of this Ordinance.

20 **Sec. 16-2-5. Amendments to Previously Approved Subdivision Plans**

21 **(a) Scope.** Any change in an approved final subdivision plan including but not limited to
22 lot lines, road layout, and location of structures and improvements must be reviewed
23 and approved by the Planning Board. De minimis changes to an approved subdivision
24 plan may be placed on the Planning Board Consent Agenda at the discretion of the
25 Planner.

26 **(b) De minimis Changes.** De minimis changes shall not include (1) an increase in the
27 number of lots or units, (2) a change to a public or private right-of way or easement,
28 (3) a decrease in proposed buffering or landscaping, or (4) any issue involving a
29 condition placed on the Subdivision approval. Prior to placement on the Consent
30 Agenda, the applicant shall meet with the Planner to review the proposed changes
31 and shall provide eight (8) copies of the revised recording plat to the Planner at least
32 eighteen (18) days prior to the next regular Planning Board meeting. The decision of
33 the Planner to not place an item on the Consent Agenda may be appealed to the
34 Planning Board upon submission of fourteen (14) copies of the proposed change to
35 the Planner eighteen (18) days prior to the next Planning Board meeting.

36 **(c) Procedure.** A public hearing may be held concerning a subdivision amendment as
37 prescribed in Sec. 16-2-1(b). The Planning Board may request the submission of
38 information included in Appendix A or B and shall review the subdivision
39 amendment for compliance with the standards in Sec. 16-3-1. All amended plans
40 must make specific reference to the original plan and its recording information. The
41 Planning Board Decision shall be to approve, approve with conditions or deny the
42 subdivision amendment.

43 **(d) Subdivision vacation.** Once a subdivision has been recorded, a subdivision where no
44 lots have been sold or the entire subdivision is owned by one entity and no alteration
45 to commence the subdivision has occurred on the site, may be vacated in its entirety
46 by a vote of the Town Council. Anything less than a complete vacation of the

1 subdivision must be submitted to the Planning Board as an amendment. Approval by
2 the Town Council to vacate the subdivision must be recorded in the Cumberland
3 County Registry of Deeds.
4

5 **Sec. 16-2-6. Post Approval Requirements.**

6 **(a) Satisfaction of Planning Board Conditions of Approval.** Following the Planning
7 Board Decision, the subdivision plans and materials shall be revised by the applicant
8 to comply with any conditions placed on the approval by the Planning Board. Two (2)
9 sets of revised plans shall be submitted to the Planner. The Planner, and other town
10 staff as necessary, shall review all plans for compliance with the Planning Board
11 conditions of approval. The Planner shall determine whether the plans have been
12 revised to comply with the Planning Board approval. If the applicant fails to obtain
13 confirmation from the Planner that the plans are in compliance with the conditions
14 placed on the approval, the applicant may submit the revised subdivision plans to the
15 Planning Board in accordance with Sec. 16-2-3(a)(1) for minor subdivisions or Sec.
16 16-2-4(c)(1) for major subdivisions.

17 **(b) Plan Recording.** Once the plans are determined to be in compliance with the
18 Planning Board approval, the recording plan shall be properly signed by a majority of
19 the Planning Board, and shall be recorded by the subdivider in the Cumberland
20 County Registry of Deeds. If the subdivision approval includes phasing of the
21 subdivision, the recording plan shall depict all phases of the subdivision. Any final
22 plans not so recorded within ninety (90) days following the date of Planning Board
23 Decision shall become null and void. The applicant may request, prior to the
24 expiration date, that the Planning Board grant an extension due to particular
25 circumstances of the applicant which extension shall not exceed an additional period
26 of ninety (90) days. Once recorded, the subdivider shall provide the Planner with
27 three (3) paper copies of the subdivision plat with the Planning Board signatures and
28 the book and page recording information from the Registry of Deeds.
29

30 **(c) Performance Guarantee.** There shall be no sale of lots, nor building permits issued,
31 nor site work commenced until a Performance Guarantee has been approved and
32 posted with the Town of Cape Elizabeth Town Manager.
33

34 1. Form. The Performance Guarantee shall be in the form of an irrevocable letter
35 of credit or escrow account in favor of the Town. Such Performance
36 Guarantee shall be satisfactory to the Town Manager and to the Town
37 Attorney as to the issuer, substantive sufficiency, surety and manner of
38 execution. All performance guarantees shall contain a provision requiring the
39 issuer to notify the Town Manager in writing of the scheduled expiration date
40 at least thirty (30) days and not more than ninety (90) days in advance of its
41 scheduled expiration date. Extensions of the Performance Guarantee may be
42 granted by the Town Manager for up to three (3) years from the initial
43 expiration date at the request of the applicant for good cause.
44

45 2. Amount. The Performance Guarantee amount shall be based on a detailed
46 estimate prepared by the applicant, broken down by unit cost and quantity,

1 and reviewed by the Town Engineer. Costs included in the estimate shall
2 include, but not be limited to completion of all roads, sewer, water, drainage,
3 open space, landscaping, lighting and other required improvements shown on
4 the approved plans. The cost estimate shall also include a contingency amount
5 equal to ten (10) percent of the Performance Guarantee estimate.
6

7 3. Phasing. When the Planning Board has approved phasing of a subdivision, a
8 Performance Guarantee may be posted for one (1) or more phases. The
9 amount, terms and conditions of the Performance Guarantee shall correspond
10 with the phase or phases scheduled to be constructed. Construction activity
11 shall only be located in phases for which a Performance Guarantee has been
12 posted.
13

14 4. Reductions and Release. All requests for reduction or release of the
15 Performance Guarantee shall be submitted to the Town Manager. Reduction
16 requests should only be submitted after significant construction has been
17 accomplished. Prior to approving a reduction or release of a Performance
18 Guarantee, the Town Manager shall request a report from the Town Engineer
19 confirming the quality and value of the construction completed. Any
20 reduction or release shall preserve the Town's ability to require or complete
21 construction that is consistent with the approved plans and the town's
22 construction standards and/or restore and stabilize the site if construction will
23 not be continued. There shall be no final release of any Performance
24 Guarantee until the record drawings have been received and approved by the
25 Town Engineer.
26

27 **(d) Inspection Fee.** In addition to the Performance Guarantee, the applicant shall pay an
28 inspection fee. When the performance guarantee equals five hundred thousand
29 dollars (\$500,000) or less, the inspection fee amount shall be five percent (5%) of the
30 cost of the total performance guarantee. When the performance guarantee exceeds
31 five hundred thousand dollars (\$500,000), the inspection fee amount shall be two and
32 one-half percent (2.5%) of the cost of the total performance guarantee. The fee shall
33 be payable by certified check to the Town of Cape Elizabeth. The inspection fee shall
34 be held by the Town to defray the Town's cost for inspection by the Town Engineer
35 and Town staff. Any funds not disbursed for this purpose shall be returned to the
36 applicant upon release of the performance guarantee. If the costs for inspection
37 exceed the amount of the Inspection Fee, the applicant shall pay an additional fee to
38 the Town which shall be recommended by the Town Engineer and approved by the
39 Town Manager based on the status of the development.

40 **Sec. 16-2-7. Construction Administration**

41 **(a) Commencement of Construction.** At least ten (10) days prior to commencing
42 construction of required improvements, the subdivider shall request a pre-
43 construction meeting with the Town Manager. At the meeting, the subdivider shall
44 submit plans for construction of the subdivision and notify the Town Manager when
45 construction of such improvements will commence. The subdivider is also
46 responsible for communicating ongoing progress of construction so that the Town can

1 cause inspections and so that requirements shall be met during construction and to
2 assure satisfactory completion of all improvements and utilities required by the
3 Planning Board. [Revised eff. 11/11/83; Revised eff. 6/13/90]
4

5 **(b) Notice of Inspection.** To assure proper inspection of roads and other required
6 improvements, the Town Engineer should be given not less than twenty-four (24)
7 hour notice by the subdivider for inspections required at the following construction
8 stages: (1) before backfilling of any surface water, sanitary sewer, domestic water or
9 other underground lines or improvements, (2) at completion of road subgrades and
10 after installation of gravel surface, (3) at the commencement of paving, loaming, or
11 other final surface preparation, and (4) upon final completion.
12

13 **(c) Inspection of Required Improvements.** All required subdivision improvements for
14 which a Performance Guarantee are required shall be constructed under the
15 observation of a qualified construction monitor. The qualifications of the construction
16 monitor shall be subject to the review and approval of the Town. Construction
17 monitoring costs shall be borne by the subdivider. The construction monitor shall be
18 on the site during all periods of time when significant construction is taking place.
19 Significant construction shall include (1) embankments, (2) bedding and backfilling
20 of all underground utilities including water lines, unless the installation is supervised
21 by the utility company, (3) installation of storm drainage and associated structures,
22 (4) installation of sanitary sewers and associated structures, (5) roadway subbase
23 material, (6) roadway base material, (7) paving, (8) compaction testing, and (9) sewer
24 and manhole testing. The duties of the construction monitor shall also include (1)
25 knowledge of product reports and material submittals, (2) maintenance of a diary of
26 construction progress, and (3) implementation of remedial measures.

27 **(d) Authority of Town Engineer.** The Town Engineer shall have access to the site at all
28 times to review the progress of the work and shall have the authority to review the
29 field logs maintained by the construction monitor. Any deficiencies noted by the
30 Town Engineer shall be brought to the attention of the construction monitor who shall
31 see that remedial measures are taken.
32

33 If the Town Engineer finds upon inspection of required improvements, including an
34 inspection to be done by the engineer before expiration of the Performance
35 Guarantee, that any of such improvements are not constructed in accordance with
36 plans and specifications filed by the subdivider, or that in the Town Engineer's
37 judgment the applicant will be unable to complete the required improvement within
38 the period specified in the Performance Guarantee, the Town Engineer shall then so
39 notify the subdivider and the Town Manager, who shall take all necessary steps to
40 preserve the rights of the Town under the Performance Guarantee, including
41 authorization to the Town Engineer to stop the construction of said improvements.
42

43 **(e) Field Changes.** If at any time before or during the construction of the required
44 improvements the subdivider demonstrates to the satisfaction of the Town Engineer
45 that unforeseen conditions make it desirable to modify the design of such
46 improvements, the Town Engineer may, in consultation with the Public Works

1 Director and Planner, authorize modifications provided that they are within the spirit
2 and intent of the Planning Board approval and do not constitute waiver or substantial
3 alteration of the function of any improvements required by the Planning Board. The
4 Town Engineer shall issue any authorization under this section in writing, and shall
5 transmit a copy of such authorization to the Planner and Planning Board.
6

7 **(f) Record drawings.** Upon completion of construction, the subdivider shall present to
8 the Town one (1) set of reproducible mylar, one (1) hard copy, and one (1) electronic
9 file of record drawings indicating facilities as constructed. The record drawings shall
10 be based on the field logs of the construction monitor and of a quality acceptable to
11 the Town. The record drawings shall include an engineer's seal, distances, angles and
12 bearings for complete and accurate determinations of locations on the ground, right-
13 of-way monuments and as set, as-built profiles of the centerlines of traveled ways,
14 ledge elevations encountered during construction and information on the locations,
15 size, materials and elevations of storm drains, sanitary sewers and other underground
16 utility lines, including but not limited to water, electric, telephone, natural gas, cable
17 television.

18 **(g) Completion and Acceptance.** Upon completion of the subdivision infrastructure, the
19 subdivider may request that the Town Council accept proposed public improvements.
20 The request shall include confirmation from the Town Manager that the
21 improvements have been constructed consistent with the approved plans and town
22 construction standards and that any applicable deeds have been submitted in a form
23 acceptable to the Town Attorney and signed by the subdivider. The applicant shall be
24 required to maintain all improvements and to provide for snow removal on roads and
25 sidewalks, until their acceptance by the Town or the assumption of those
26 responsibilities under such other approved arrangements.

27 28 **Article III. Standards**

29
30 **Sec. 16-3-1. Subdivision Review Standards.** A subdivision shall meet all of the
31 following standards of review, as determined by the Planning Board.

32 **(a) Pollution**

33 The proposed subdivision will not result in undue water or air pollution. Factors to
34 consider include:

- 35 1. The elevation of the land above sea level and its relation to the floodplains.
- 36 2. The nature of soils and subsoils and their ability to adequately support waste
37 disposal.
- 38 3. The slope of the land and its effect on effluents.
- 39 4. The availability of streams for disposal of effluents.
- 40 5. The applicable state and local health and water resource rules and regulations.

41 **(b) Sufficient Potable Water**

1 The proposed subdivision has sufficient water available for the reasonably
2 foreseeable needs of the subdivision. If a public water supply will be used, the
3 proposed subdivision will not cause an unreasonable burden on the existing public
4 water supply.

5 **(c) Erosion**

6 The proposed subdivision will not cause unreasonable soil erosion or a reduction in
7 the land's capacity to hold water so that a dangerous or unhealthy condition results.

8 **(d) Traffic**

9 1. Road congestion and safety. The proposed subdivision will not cause unreasonable
10 highway or public road congestion or unsafe conditions with respect to the use of the
11 highways or public roads existing or proposed, and if the proposed subdivision
12 requires driveways or entrances onto a state or state aid highway located outside the
13 urban compact area of an urban compact municipality as defined by Title 23,
14 M.R.S.A. Section 745, the Department of Transportation has provided documentation
15 indicating that the driveways or entrances conform to Title 23, M.R.S.A Section 704
16 and any rules adopted under that section.

17 2. Comprehensive Plan. The proposed subdivision road(s) shall conform to the
18 Comprehensive Plan as adopted in whole or in part by the Town Council.

19
20 3. Connectivity. The Planning Board may require provision for the projection of roads
21 or for access to adjoining property, whether subdivided or not. The Planning Board
22 shall require that access from the subdivision to previously existing or proposed
23 public ways include two means of such vehicular access, as described in Sec. 16-3-
24 2(5), Dead End Roads.

25
26 4. Safety. All roads within a subdivision and roads providing access to a subdivision
27 shall be designed so that they will provide safe vehicular and pedestrian travel and
28 traffic patterns.

29
30 5. Through traffic. The Planning Board may require that local roads be laid out so that
31 their use by through traffic will be discouraged.

32
33 6. Topography. Roads in the proposed subdivision shall be laid out in an attractive
34 manner, in order to enhance the livability and amenity of the subdivision. Insofar as
35 possible, roads shall conform to existing topography, and high cuts and fills shall be
36 avoided.

37
38 7. Block Length. Block lengths shall not exceed one thousand (1,000) feet except
39 where a greater length suits the topography or character of the subdivision and does
40 not result in an awkward road pattern or detrimental effect to adjacent property.

41
42 8. Lot Access. Each property shall be provided with vehicular access to each lot by
43 an abutting public or private road. A private road shall be protected by a permanent

1 easement which shall conform to the Road Classification Standards Table and which
2 shall be shown on the plan.

3
4 9. Sidewalks/pedestrian connections. The Planning Board may require sidewalks
5 and/or curbing on either or both sides of any road, where they are or may be
6 necessary for maintenance and/or public safety, as determined by the Planning Board.
7 Provision of pedestrian easements or other types of pedestrian accessways not less
8 than ten (10) feet wide may be recommended to the applicant, where a pedestrian
9 accessway would add to the Town's Greenbelt System or where the Planning Board
10 deems it important for pedestrian enjoyment or to provide access to but not limited to
11 schools, playgrounds, shopping centers, recreation areas, open space, trails, shore
12 frontage, and other facilities. Where feasible, the easements shall connect to existing
13 and proposed recreation trails.

14
15 10. Road Name. Road names shall not be used which will duplicate or may be
16 confused with the names of existing roads. Road names shall be subject to the
17 approval of the Planning Board and be in compliance with the Addressing Ordinance,
18 Chapter 21, as determined by the Police Chief.

19
20 11. Road Construction Standards. Proposed roads are designed in compliance with
21 the Road Construction and Design Standards, Sec. 16-3-2.

22
23 **(e) Sewage Disposal**

24
25 The proposed subdivision will provide for adequate sewage disposal and will not
26 cause an unreasonable burden on municipal services if they are utilized. All systems
27 proposed for the disposal of sewage for developments regulated by this Ordinance
28 shall be in compliance with the provisions of Chapter 15, Sewer Ordinance.

29
30 **(f) Solid Waste Disposal**

31
32 The proposed subdivision will provide for adequate disposal of solid waste. The
33 proposed subdivision will not cause an unreasonable burden on the municipality's
34 ability to dispose of solid waste, if municipal services are to be utilized.

35
36 **(g) Aesthetic, cultural and natural values**

37
38 The proposed subdivision will not have an undue adverse effect on scenic or natural
39 areas, aesthetics, historic sites, significant wildlife habitat identified by the
40 Department of Inland Fisheries and Wildlife or the municipality, or rare and
41 irreplaceable natural areas or any public rights for physical or visual access to the
42 shoreline.

43
44 1. Scenic. Consideration shall be given by the applicant and the Planning Board to
45 the impact of the proposed development on scenic vistas and view corridors to and
46 from significant natural features, historic sites, and important topographic features as

1 identified in the Town's Comprehensive Plan. The Planning Board may consider the
2 impact of other design features such as building bulk, architectural style, building
3 placement and landscaping to encourage visual harmony.
4

5 2. Wildlife. The applicant shall make adequate provision for the protection of
6 wildlife habitat and fisheries areas, which may include but are not limited to
7 maintenance of wildlife travel lanes, and the preservation and buffering of wildlife
8 habitat areas from proposed development activities.
9

10 3. Natural features. The applicant, whenever practical, shall be required to preserve
11 natural features such as water courses or bodies, existing trees of ten (10) inches or
12 more in diameter (base height), open space, scenic points, historic spots, and unusual
13 or striking topographic features which, if preserved, would add to the attractiveness of
14 the subdivision.
15

16 4. Farmland. All farmland within the proposed subdivision has been identified on
17 maps submitted as part of the application.
18

19 **(h) Conformity with local ordinances**
20

21 1. Comprehensive Plan. The proposed subdivision is consistent with applicable
22 provisions of the Comprehensive Plan.
23

24 2. Zoning Ordinance. The area and width of lots shall conform to the requirements of
25 the Zoning Ordinance. Side lot lines shall be substantially at right angles or radial to
26 road lines.
27

28 3. Multiplex Housing. Multiplex housing and cluster developments shall be so
29 designed, sited and laid out as to minimize disturbance of existing topography and
30 ground cover, provide maximum usable natural or improved open space, reflect
31 imaginative use of the site, and be compatible with any surrounding land uses and
32 their character. The minimum lot size and density requirements for any proposed
33 multiplex housing or cluster development shall comply with the Zoning Ordinance.
34

35 4. Addressing Ordinance. The street numbering of the individual residential dwelling
36 units and/or lots must be clearly visible on the plans and shall be done in compliance
37 with the Addressing Ordinance, Chapter 21. For any development with more than one
38 set of attached or multiplex dwelling units, signs clearly identifying the house
39 numbers in each set of dwelling units shall be required to be placed along the road
40 leading to each set of units and shall be subject to approval of the fire chief and police
41 chief.
42

43 **(i) Financial and Technical Capability**
44

45 The applicant shall demonstrate adequate technical and financial capability to
46 complete the project as proposed. In the case where the applicant asserts that public

1 disclosure of confidential financial information may prove detrimental to the
2 applicant or to the success of the subdivision, the Town Manager may review the
3 financial records of the applicant and recommend to the Planning Board that financial
4 capability is adequate.

5
6 **(j) Surface Waters**

7
8 Whenever situated entirely or partially within the watershed of any pond or lake or
9 within two hundred fifty (250) feet of any wetland, great pond or river as defined in
10 Title 38, M.R.S.A. Chapter 3, subchapter I, article 2-B, the proposed subdivision will
11 not adversely affect the quality of that body of water or unreasonably affect the
12 shoreline of that body of water. The Planning Board may determine that the proposed
13 subdivision will not adversely affect surface water quality if the subdivision has been
14 designed to comply with the Shoreland Performance Overlay District.

15
16 **(k) Ground Water**

17
18 The proposed subdivision will not, alone or in conjunction with existing activities,
19 adversely affect the quality or quantity of ground water.

20
21 **(l) Flood Areas**

22
23 The Planning Board shall review all subdivision proposals to assure that: (1) they are
24 designed to minimize flood damage; (2) all public utilities and facilities, such as
25 sewer, gas, electrical, and water systems are located, elevated, and constructed to
26 minimize or eliminate flood damage; (3) adequate drainage is provided so as to
27 reduce exposure to flood hazards; and (4) the proposed subdivision otherwise meets
28 the standards of the Town's Floodplain Ordinance, Sec. 6-6.

29
30 **(m) Wetlands**

31
32 Any proposed alteration of wetlands shall adhere to the requirements and standards of
33 Section 19-6-9 and Section 19-8-3 of the Zoning Ordinance.

34
35 **(n) Stormwater**

36
37 The proposed subdivision will provide for adequate stormwater management.

38
39 For any subdivision involving more than 10,000 square feet of impervious surface,
40 paving, clearing or vegetative alteration, the provisions and improvements for the
41 control of storm water runoff shall be governed by the provisions of Chapter 18,
42 Article II, Storm Water Control Ordinance. In the case of any subdivision involving
43 less than 10,000 square feet of such impervious surfaces, where a subdivision is
44 traversed by a stream, drainage way or other watercourse, or where the Planning
45 Board with the advice of the engineer feels that surface water drainage to be created
46 by the subdivision should be controlled for the protection of the subdivision and

1 owners of property abutting it, there shall be provided an easement or drainage right-
2 of way conforming substantially with the lines of such watercourse, and culverts,
3 catch basins or other means of channeling surface water within such subdivision and
4 over the property of owner abutting upon it of such nature, width and location as the
5 Planning Board with the advice of the engineer, deems adequate.
6

7 **(o) Lake Phosphorus concentration**
8

9 The long term cumulative effects of the proposed subdivision will not unreasonably
10 increase a great pond's phosphorus concentration during the construction phase and
11 life of the proposed subdivision. The Planning Board may consider compliance with
12 the Great Pond Watershed Overlay District, Sec. 19-6-12, Zoning Ordinance, as
13 demonstration of no unreasonable increase.
14

15 **(p) Impact on adjoining municipality**
16

17 For any proposed subdivision that crosses municipal boundaries, the proposed
18 subdivision will not cause unreasonable traffic congestion or unsafe conditions with
19 respect to the use of existing public ways in an adjoining municipality in which part
20 of the subdivision is located.
21

22 **(q) Land subject to Liquidation Harvesting**
23

24 The proposed subdivision is not located on land where timber has been harvested in
25 violation of rules adopted pursuant to Title 12 M.R.S.A. Section 8869, subsection 14
26 or the violation occurred at least five (5) years before the subdivision application has
27 been submitted.
28

29 **(r) Access to Direct Sunlight**
30

31 Consideration shall be given by the applicant and the Planning Board to the
32 sensitivity of the proposed subdivision design for the purpose of protecting and
33 assuring access to direct sunlight. The Planning Board may, to protect and ensure
34 access to direct sunlight for solar energy systems, prohibit, restrict, or control
35 development through methods such as but limited to restrictive covenants, height
36 restrictions, and side yard and setback requirements.
37

38 **(s) Buffering**
39

40 Plants or other types of vegetative cover shall be preserved or placed throughout and
41 around the perimeter of any proposed subdivision to provide for an adequate buffer,
42 reduction of noise and lights, separation between the subdivision abutting properties,
43 and enhancement of its appearance.
44

1 Off-road parking lots, storage areas, rubbish disposal areas, or similar improvements
2 exposed to public roads or to residential areas shall be screened by walls, earth berms,
3 fences, or vegetation, and shall be properly landscaped.

4
5 **(t) Open Space Impact Fee**
6

- 7 1. Purpose. In order to accommodate the expected needs of the subdivision for open
8 space and recreational areas without diminishing the community standard of
9 public open space, the applicant shall be required to donate land with legal public
10 access or a cash contribution in lieu of actual land dedication, or a combination of
11 both, at the option of the Planning Board and with the advice of the Conservation
12 Commission.
13
- 14 2. Community Standard. Public open space shall include the inventory of open space
15 for which there is legal public access, including:
16 i. Open space owned by the Town;
17 ii. Open space encumbered by an easement owned by the Town which allows
18 public access;
19 iii. Open space owned by the Cape Elizabeth Land Trust; and
20 iv. Open space encumbered by an easement owned by the Cape Elizabeth Land
21 Trust which allows public access. The Community Standard of public open
22 space shall be defined as the total acreage of open space divided by the
23 Town's population, as of the most recent U.S. Census.
24
- 25 3. Land donation. The required land donation of open space shall be calculated by
26 multiplying the number of lots/units in the proposed subdivision by the average
27 number of persons per household as published in the most recent U.S. Census,
28 and then multiplying the resulting number by the Community Standard of public
29 open space. At least twenty percent (20%) of the land donated shall be land which
30 is not a Resource Protection Zone or buffer and has a slope not to exceed fifteen
31 percent (15%).
32
- 33 4. Fee. If the resulting land dedication would be too small to be useful, or
34 inappropriately located, the Planning Board may require the applicant to pay a fee
35 in lieu of all or part of the required land dedication. The fee shall be calculated by
36 multiplying the amount of acreage which otherwise would have been required to
37 be donated with the proposed subdivision (rounded to the nearest one-hundredth
38 of an acre) by the average fair market value of one acre of vacant land (rounded to
39 the nearest dollar) determined by the Town Assessor using accepted professional
40 valuation methods.
41
- 42 5. Administration. The type of land donated and land conveyance by fee ownership
43 deed or easement shall be consistent with the land included in the town inventory.
44 Open space impact fees shall be segregated from the Town's general revenues and
45 expended only for the acquisition or improvement of public open space. The
46 Town shall refund to the applicant that portion of the collected open space impact

1 fee that is not expended within ten (10) years from the date of receipt. The
2 Community Standard of public open space, average fair market value of one acre
3 of vacant land, and open space impact fee therein derived shall be published in the
4 Fee Schedule approved and periodically updated by the Town Council. The Fee
5 Schedule shall be available for inspection at the office of the Town Clerk. Any
6 required fee shall be paid prior to the commencement of construction of the
7 subdivision and/or issuance of a building permit.

8
9 **(u) Utility Access.**

10 All lots shall have access to water, electrical, and telephone and other utilities.

11
12
13 **(v) Phasing.**

14
15 If a subdivision is proposed for development in phases, no portion of the subdivision
16 may be left out of the phasing plan. Sequence of construction of subdivision phases
17 shall be determined. Each phase or, as applicable, sequence of phases shall preserve
18 the standards of review of Sec. 16-3-1, with emphasis on emergency vehicle access.
19 The Planning Board may impose such conditions as it deems necessary to assure the
20 orderly development of the subdivision to assure that all necessary improvements are
21 made for each separate phase.

22
23 **Sec. 16-3-2. Road Design and Construction Standards** The purposes of the subdivision
24 road standards are to minimize traffic safety hazards and the cost of municipal
25 maintenance and reconstruction, to ensure that roads are consistent with the Town's rural
26 character, to promote a sense of community, and to be consistent with the Comprehensive
27 Plan. The standards shall be flexible where an applicant can demonstrate that alternative
28 approaches will meet the above stated purposes. Roads within a subdivision shall be
29 classified by the Planning Board in accordance with their location and their present and
30 contemplated usage. A road which is likely to be upgraded in classification in the
31 foreseeable future shall be laid out to the standards of the potential future classification.
32 The widths and grades for all subdivision roads shall be determined in accordance with
33 the **Road Classification Standards Table**, subject to the following qualifications:

- 34
35 1. Where an existing road with right-of-way of less than fifty (50) feet is being
36 extended, the new right-of-way may be the same width as the existing road upon
37 approval by the Planning Board and Public Works Director.
38
39 2. Width of right-of-way may be forty (40) feet for a road shorter than three-hundred
40 (300) feet which ends in a cul-de-sac, upon approval by the Planning Board and
41 Town Engineer.
42
43 3. Notwithstanding the **Road Classification Standards Table**, dead-end roads in excess
44 of one thousand (1,000) feet in length must comply with Sec. 16-3-2 (a)(9).
45
46

1 **A. Road Design**

2 1. Sight Distance

3
4 **a. New Subdivision Road sight distance.**

5
6 (1) Measurement. Sight distance shall be measured from a height 3.5 (three
7 and one half) feet above the traveled way, in each direction of the road to a
8 height.5 (one-half) foot above the pavement.

9 (2) Standard. The road shall be designed to achieve a sight distance in the
10 range indicated on the **Road Classification Standards Table**. The maximum
11 sight distance range shall not be exceeded without reasonable justification
12 which shall be presented by the applicant.

13
14 **b. Road Intersections.**

15
16 (1) Measurement. The sight distance for a road entering onto a second road
17 shall be measured from a location fifteen (15) feet behind the edge of traveled
18 way of the side road or drive at an elevation of three and one half (3.5)feet
19 above the finished grade surface to a point four and one quarter (4.25) feet
20 above the pavement in the centerline of the travel lane approaching the
21 intersection. Where unavoidable obstructions are encountered at the fifteen
22 (15) foot setback, the location may be moved to a point no closer than ten (10)
23 feet from the traveled way. Isolated interruptions of minimal time duration in
24 sight distance due to obstructions, such as a single tree, shall not be included
25 in the measurement of sight distance.

26
27 (2) Standard. The road intersection shall be designed to achieve a sight
28 distance in the range indicated on the **Road Classification Standards Table**.

29
30 **c. Single Family driveways.** When the Planning Board requires that an
31 individual driveway be shown on the subdivision plan, the sight distance
32 measurement and standard shall meet the requirements in the **Road**
33 **Classification Standards Table**.

34
35 2. Road Geometry. New subdivision roads shall be designed to comply with the
36 **Road Classification Standards Table** and the following standards:

37
38 **a. Horizontal Alignment.** At all changes in alignment, road sidelines shall be
39 connected by horizontal curves. All changes in slope shall be connected with
40 vertical curves whose length shall be consistent with the **Road Classification**
41 **Standards Table**. When the degree of curvature exceeds two (2) degrees on
42 rural connector, collector, or arterial roads, the curves shall be super-elevated
43 to meet the criteria established by AASHTO, most current edition.

44
45 (1) Intersection Design

1
2
3
4
5
6
7
8
9
10
11
12
13
14
15
16
17
18
19
20
21
22
23
24
25
26
27
28
29
30
31
32
33
34
35
36
37
38
39
40
41
42
43
44
45

- i. Roadway grades approaching an intersection shall not exceed three (3) percent for a distance of fifty (50) feet from the edge of paving of the road being entered.
 - ii. Road intersections shall be separated at least one hundred twenty-five (125) feet whenever possible.. A separation of less than one hundred twenty-five (125) feet may be acceptable when a low volume of traffic allows for safe traffic circulation.
 - iii. At intersections and common boundaries of subdivisions, roads shall be continuous and in alignment with existing roads if possible. Roads shall be laid out so as to intersect as nearly as possible at right angles, and no road shall intersect any other road at less than a sixty (60) degree angle.
- b. Traveled Way.** The traveled way shall be designed consistent with the **Road Classification Standards Table**. Every traveled way shall maintain a constant width and shall be centered in its right-of-way. The Planning Board may also shift the traveled way up to five (5) feet from the center to preserve existing mature trees or minimize wetland alterations.
- c. Radii.** Radii of curves and lengths of tangents between curves shall be consistent with the **Road Classification Standards Table**. At a minimum, road radii shall provide adequate turning radius for a B-40 vehicle as defined by AASHTO. To measure turning radius, the full width of pavement of both lanes of traffic shall be included, exclusive of shoulder areas. Minimum turning radius shall be required from both directions of the intersecting road.
- d. Shoulders.** The width of shoulders and surfacing shall be determined by reference to the **Road Classification Standards Table**. The road lanes shall be striped to provide a traveled way in compliance with the **Road Classification Standards Table**.
3. **Sidewalks.** Sidewalks shall be five (5) feet wide and shall be separated from the traveled way by a grassed esplanade in accordance with the **Road Classification Standards Table**. When locating the sidewalk, a one (1) foot wide buffer strip shall be preserved along the right-of-way between the back edge of the sidewalk and the right-of-way. Sidewalks shall be required on one side of the road and notwithstanding Sec. 16-3-5, shall not be waived by the Planning Board. The design of a Rural Connector shall include a sidewalk path within ten (10) feet of the outside edge of the right-of-way. The sidewalk path shall be field located to avoid significant vegetation. (Revised eff 12/10/03)
4. **Curbing.**

- 1 a. Curbing shall be installed at road intersections and have a radius of at least
2 twenty-five (25) feet, unless otherwise approved by the Town Engineer.
3 Curbing may be required to aid in slope stabilization . (Revised eff 12/10/03)
4
- 5 b. Curbing shall consist of granite, extruded concrete or bituminous concrete;
6 design and choice of materials for curbing shall be based upon the anticipated
7 use of the road involved and shall be subject to the approval of the Town
8 Engineer and the Public Works Director. Granite curbing specifications shall
9 be five inch by seventeen (5 x 17) inch vertical plus or minus one (1) inch
10 vertical as required by the Public Works Director. Granite curbing installed at
11 intersection shall be set in concrete.
12
- 13 5. Drainage. All roads shall have an underground enclosed drainage system, and no
14 surface drainage shall be conveyed or diverted across a traveled way.
15
- 16 6. Road Signs. Road signs shall be approved by the Public Works Director and
17 installed in compliance with MUTCD (Manual on Uniform Traffic Control
18 Device) standards .
19
- 20 7. Road Trees.
21
- 22 a. Each road shall be designed to include, within the right-of-way, at least one
23 (1) tree for every forty (40) feet of road frontage but not less than two (2) trees
24 per lot. All trees shall comply with tree species and size standards approved
25 by the Town Tree Warden. Existing trees within the right-of-way which have
26 been preserved may be counted toward this requirement if the species, size,
27 preservation measures, and post-construction condition of the trees are
28 approved by the Tree Warden. Where an esplanade is included in the road
29 design, road trees required on that side of the street shall be planted in the
30 esplanade. The esplanade shall be filled with soil, such as common borrow,
31 suitable for growing trees. See also Appendix C, Road Tree List.
32
- 33 b. Landscaping including trees and other plant materials shall be required in the
34 center island of a cul-de-sac.
35
- 36 8. Dead-End Roads
37
- 38 a. Dead-end roads shall not be longer than two thousand (2,000) feet in length
39 and shall not serve more than twenty (20) dwelling units. The maximum
40 length, the maximum number of dwelling units and the mandatory
41 requirements of dead-end roads shall not be waived by the Planning Board,
42 notwithstanding the waiver provision in Sec. 16-3-5.
43
- 44 b. Any dead-end road in excess of one thousand (1,000) feet in length shall meet
45 mandatory requirements for the entire length of the dead-end road.
46 Mandatory requirements shall include (1) the placement of all utilities

1 underground, (2) the dedication to the town of a fifty foot wide right-of-way,
2 and (3) a minimum pavement width of twenty-two (22) feet.

3 c. The Planning Board may require improvements such as (1) the placement of
4 sidewalks to town specifications, (2) limited clearing of the right of-way with
5 the advice of the tree warden on the stability of adjacent tree growth, (3) the
6 provision of an emergency access lane with a minimum width of eighteen (18)
7 feet and (4) a minimum esplanade width of six (6) feet for divided entrances.

8
9 d. A dead-end road shall be measured from the end of the existing or proposed
10 dead-end road to the closest intersecting through road. The measurement shall
11 include proposed road(s) and existing road(s), public or private, whether
12 within or beyond the limits of the proposed subdivision. The length of the
13 road shall be measured from the center line of the closest through road, along
14 the center line of the dead-end road to the end of pavement or traveled way.
15 Divided entrances shall be allowed only if they provide direct access to
16 arterial roads as classified by the town.

17
18 e. All dead-end roads shall end in a cul-de-sac or a T-shaped turnaround and be
19 designed according to the dimensions shown on Appendix D.. All cul-de-sacs
20 shall be so designed that water will drain from all portions into a storm water
21 drainage system. The interior of all cul-de-sacs shall be neat and orderly, and
22 shall either be left in its natural condition or be graded, loamed and seeded.
23 Granite monuments shall be installed by the developer at the intersection of
24 each side of the road with the cul-de-sac and at the radius point of the cul-de-
25 sac, as shown in the cul-de-sac diagrams.

26
27 A T or L-shaped turnaround may be used and placed on the right side of the
28 road. All T-shaped turnarounds, whether temporary or permanent, shall be
29 paved. No parking is allowed in a turnaround. See also Appendix D,
30 Turnaround Design.

31 9. Private Road. The first fifty (50) feet of a private road from the edge of the road
32 shall be paved. A private road shall be constructed in accordance with the right-
33 of-way width, gravel base, traveled way width and monumentation of a local
34 road. The Planning Board may require that a road be constructed to public road
35 standards; further the Planning Board shall require dedication of the roads as
36 public rights-of-way if there is potential for future development that could be
37 accessed through the proposed subdivision.

38
39 10. Monuments. A four (4) inch square granite monument shall be set at each point
40 of curvature and angle point on both sides of every road and at every property line
41 intersection. A surveyor's pin shall be set at each property line corner. Except
42 with the permission of Public Works Director, all monumentation shall set flush
43 with existing grade. At road intersections and at locations where monuments on
44 one road line would fall within two hundred (200) feet of each other, the Public
45 Works Director may reduce this requirement provided that the reduced
46 monumentation is adequate for road line surveys.

1
2
3
4
5
6
7
8
9
10
11
12
13
14
15
16
17
18
19
20
21
22
23
24
25
26
27
28
29
30
31
32
33
34
35
36
37
38
39
40
41
42
43
44
45

B Road Construction

1. Clearing

- a. Prior to site alteration, a land surveyor registered in the State of Maine shall mark the layout of the road and verify for the Town Engineer that the layout is in conformance with the approved plans.
- b. The construction area shall be selectively cleared of all trees, brush and vegetation only as necessary for construction of the roadway, shoulder, utilities and any drainage ways as approved by the Planning Board. Clearing provisions shall be accomplished in accordance with the most recent revision of the Standard Specifications of the Maine Department of Transportation, Section 201.
- c. Limits of clearing shall be marked in the field and may be inspected by the Town Engineer prior to further site preparation. In a Rural Connector, a ten (10) foot wide strip shall be preserved at the edge of the right-of-way, where a sidewalk path may be placed. The ten (10) foot wide strip shall be retained in a natural state and serve as a buffer, although trimming may be allowed to preserve scenic views.

2. Grading to Subgrade

The roadway shall be brought to subgrade through the process of excavation and/or placement of fill. Such earthwork shall be accomplished in compliance with the technical provisions of Section 203 of said MDOT Specifications. Blasted ledge, which is, less than fourteen (14) inches in any dimension, may be used as fill up to a level one foot and one-half (1.5) feet below subgrade, and shall be mixed with sufficient finer material to make a firm, stable embankment. Revised eff. 12/10/03)

3. Base Gravel for Roadways & Sidewalks

- a. The gravel base course shall be a minimum of one and one-half (1.5) feet in depth. When subgrade materials are marginal, the Town Engineer may require additional base gravel. The lower one (1) foot of material shall conform to the requirement of Section 703.06 (b). Types D or E of the said MDOT Specifications, except that no particle of rock shall exceed three (3) inches as determined by a three (3) inch square mesh sieve.
- b. The upper six (6) inches of material shall conform to the requirements of Section 703.06 (a). Types A and B of the said MDOT Specifications except that maximum particle size for Type B shall be three (3) inches.

- 1 c. The base gravel shall be placed and compacted in accordance with technical
- 2 requirements of Section 304 of said MDOT Specifications. Initial compaction
- 3 tests shall be taken at a minimum interval of every fifty (50) linear feet along
- 4 the roadway for each lift of material placed, and then compaction tests at a
- 5 greater separation if initial tests pass. Retesting of any failed areas must be
- 6 conducted after remedial action has been accomplished. Additional
- 7 compaction tests may be required by the Public Works Director.
- 8
- 9 d. Gravel for sidewalk base shall be eight (8) inches in depth and shall meet the
- 10 requirements of Section 703.06 (a) of said MDOT specifications, Types A,B,
- 11 or D, placed in one lift compacted to ninety-five (95) percent of optimum
- 12 density.
- 13
- 14 e. The base of the esplanade located between the road and the sidewalk shall not
- 15 be filled with gravel. The underlying material under the loam layer shall be
- 16 common borrow or a similar material conducive to tree growth. The
- 17 maximum grade of the esplanade cross-slope shall be two (2) percent.
- 18

19 4. Paving.

- 20
- 21 a. Paving shall be of Hot Mix Asphalt (HMA) meeting the requirements of
- 22 Section 401 and 403 of said MDOT Specifications. Placement of HMA shall
- 23 conform to MDOT Specifications (Section 401). Sidewalk HMA shall be
- 24 placed in two(2) one and one quarter (1.25) inch lifts using 9.5 mm mix.
- 25 HMA thickness shall be as follows:
- 26

| | Base Course 19 mm Mix unless otherwise noted | Surface Course 12.5mm Mix, except local roads which shall be 9.5mm | Surface Course 9.5 mm fine Mix | Total |
|-----------------|---|---|---|--------------|
| Arterial | 2.5inches | 1.5inches" | -- | 4 inches |
| Collector | 2.5 inches | 1.5inches | -- | 4 inches |
| Rural Connector | 2.5 inches | 1.5inches | -- | 4 inches |
| Feeder | 2.5 inches | 1.5 inches | -- | 4 inches |
| Local Roads | 2 .5" of 19 mm | 1.5 inches | -- | 4 inches |
| Sidewalks | -- | -- | 2 .5 inches | 2.5 inches |

- 27
- 28 b. The HMA base course shall be 19 mm mix for all classes of roads, except
- 29 local roads and sidewalks which shall be 9.5 mm mix as defined in Section
- 30 703.09 of said MDOT Specifications. Sidewalk paving shall be 9.5 mm (fine)
- 31 mix.
- 32
- 33 c. Placement of all HMA shall be in compliance with the technical requirements
- 34 of Section 401 of said MDOT Specifications.
- 35

- 1 d. Driveway entrances shall include a paved apron starting at the edge of road
2 pavement and extending four (4) feet toward the property being served. In
3 locations where driveways are coincident with sidewalks, the paved apron
4 shall extend from the edge of the road pavement to four (4) feet beyond the
5 back of the sidewalk. Driveway aprons shall meet the criteria for local road
6 paving.
7
- 8 e. Where bituminous or extruded concrete curbing is to be placed, the paving
9 shall extend one (1) foot beyond the back of curb to serve as a curb platform.
10
- 11 5. Curbing. Curbing shall be placed in accordance with Section 609 of said MDOT
12 Specifications. Bituminous concrete curbing shall meet the requirements of
13 Section 712.36 of said MDOT Specifications. Extruded concrete curbing shall
14 meet the requirements of Section 712.03 of said MDOT specifications. The curb
15 cross section shall be of the low profile berm curb type and shall be placed on top
16 of the HMA base course.(Revised eff. 12/10/03)
17
- 18 6. Stone Fill, Riprap, Stone Ditch Protection. When required for erosion control,
19 stone fill, riprap and stone ditch protection shall be placed in accordance with
20 Section 610 of said MDOT Specifications.
21
- 22 7. Sodding - Erosion Control Mesh.
23
- 24 a. Where required to prevent erosion and when indicated on the plans, sod shall
25 be placed in accordance with the technical requirements of Section 616 of said
26 MDOT Specifications.
27
- 28 b. When required to prevent erosion and where indicated on the plans, erosion
29 control mesh shall be placed in accordance with the technical requirements of
30 Section 613 of said MDOT Specifications.
31
- 32 8. Seeding.
33
- 34 a. All exposed slopes and areas not to be paved shall be seeded in accordance
35 with the technical requirements of Section 618 of said MDOT Specifications.
36 Seeding Method 1 shall be used.
37
- 38 b. Mulch shall be applied to all seeded surfaces in accordance with the technical
requirements of Section 619 of said MDOT Specifications.

1
2

Road Classification Standards Table

| | Right of Way | Traveled Way | Minimum Intersection Sight Distance | Width Shoulder | Horizontal Sight Distance | Design Speed | Sidewalk | Esplanade | Center Line Radius |
|--|--------------|--------------|-------------------------------------|----------------|---------------------------|--------------|----------|-----------|--------------------|
| ARTERIAL | 52' | 28' | 200' | 5' | 200-400 | 30-45 | 5' (1) | 5' | 300-800 |
| COLLECTOR | 50' | 24' | 200' | 1' | 200-250 | 30-35 | 5' (1) | 6' | 300-400 |
| RURAL CONNECTOR | 66' | 24' | 200' | 4' | 200-250 | 30-35 | 5' | 7' | 300-400 |
| FEEDER | 50' | 24' | 150' | 3' | 150-200 | 25-30 | 5' | 5' | 150-300 |
| LOCAL | 50' | 22' | 125' | 4' | 125-150 | 20-25 | 5' | 6' | 125-150 |
| (1) Either sidewalk or bikeway. Width should increase for dual purpose | | | | | | | | | |

3
4
5
6
7
8
9
10
11
12
13
14
15
16
17
18
19
20
21

See also Appendix E, Road Profiles

Sec. 16-3-3. Design of Other Improvements

A. Storm and Surface Water Drainage

1. Storm water collection and transport systems shall be designed to carry a twenty-five (25) year return frequency flow without surcharge.
2. Ditches, where permitted, on the approved plans shall have a slope of at least two (2) percent and side slopes not exceeding three to one (3:1). Where required to prevent erosion, ditches shall be riprapped, sodded, or otherwise protected.
3. Storm drain pipelines and culverts shall be installed in accordance with the technical requirements of Section 603 of said MDOT Specifications. All pipes shall be designed to withstand earth backfill plus H-20 wheel loadings. Trench backfill over drain lines within the paved way shall be compacted to ninety-five (95) percent of optimum density. Outside of paved areas backfill shall be compacted to ninety (90) percent of optimum density.

- 1 4. When required to assure a stable subbase, rigid perforated underdrain pipe shall be
2 installed in accordance with the technical requirements of Section 605 of said MDOT
3 Specifications. Coiled underdrain pipe will not be permitted. (Revised eff. 12/10/03)
4
- 5 5. Manholes and catch basins on storm drain lines shall met the technical requirements
6 of Section 6045 of said MDOT Specifications. Shop drawings for the units desired for
7 use shall be submitted to the Town Engineer for approval prior to placement.
8
- 9 6. It is specifically noted that all drainage facilities must also comply with the
10 requirements of the Town Storm Water Management Ordinance, Chapter 18
11

12 **B. Underground Utility Lines**

- 13 1. All sanitary sewer lines and appurtenances shall be constructed in accordance with
14 the requirements of the Sewage Ordinance, particularly Sec. 15-1-6 and 15-1-7.
15
- 16 2. Any road to be accepted shall be served by a water main if said road joins a road
17 containing a water main. No water main shall be less than eight (8) inches in diameter
18 unless the fire department and the Planning Board certify in writing that a water main
19 less than eight (8) inches in diameter will furnish adequate water service for the road
20 to be accepted and for any future extension of said road.
21
- 22 3. All underground utility mains shall be installed before the gravel surface is placed;
23 and, if possible utility service lines to individual lots shall be installed before gravel
24 surface is placed.
25
- 26 4. Backfill materials for all underground utilities shall be compacted to ninety-five (95)
27 percent of optimum density under paved areas and to ninety (90) percent of optimum
28 density under non-paved areas.
29

30 **Sec. 16-3-4. Additional Standards**

31 **(a) Right-of-Way.** The Planning Board with the advice of the Town Engineer may
32 require rights-of-way wider than those set forth in the **Road Classification**
33 **Standards Table**, in order to satisfy the purposes of this Ordinance.
34

35 **(b) Reserved**

36

37 **(c) Sewers .** Upon the advice of the Town Engineer, the Town Council may require a
38 applicant to construct storm or sanitary sewers at a greater depth or of larger diameter
39 than is required to serve the area being subdivided, when said greater depth or larger
40 diameter is deemed necessary to provide proper service for adjacent areas.
41

42 **Sec. 16-3-5. Waivers** Where the Planning Board finds that undue hardship, practical
43 difficulties or restriction upon imaginative and otherwise desirable design may result
44 from strict compliance with this Ordinance, it may waive one or more of the requirements
45 of this Ordinance, in favor of a proposed alternative upon a showing that, as compared
46 with strict compliance, such alternative (1) will not create more hazardous traffic

1 conditions or less sanitary sewage disposal conditions than strict compliance, (2) will
2 provide more varied and imaginative subdivision layout and design, (3) will secure
3 substantially the standards of road design and construction required by this Chapter and
4 the Zoning Ordinance, and (4) will not have the effect of nullifying the intent and
5 objectives of the Comprehensive Plan or this Chapter; provided that in granting such
6 waiver the Planning Board may impose such conditions as they deem necessary to secure
7 the foregoing objectives.

8 **Sec. 16-3-6. Legal Provisions**

9 **(a) Appeals .** All appeals from decisions of the Planning Board under the subdivision
10 regulations and the Zoning Ordinance shall be taken within thirty (30) days following
11 the date of any such decision in accordance with the provisions of Rule 80B of the
12 Maine Rules of Civil Procedure. This procedure shall apply whether or not the appeal
13 involves issues requiring an interpretation of the Zoning Ordinance.
14

15 **(b) Applicability of Road Requirements.** The provisions of the Subdivision Ordinance
16 shall serve as a guide to, but shall not be binding upon, any state, county or municipal
17 body or authority, which may lay out, alter, widen or improve any public way in
18 accordance with the applicable statutes. This Subdivision Ordinance shall not apply
19 to any roads within the Town for which road profiles had been approved by the
20 engineer prior to March 13, 1968, which were under actual construction as of March
21 12, 1968 and which had been completed not later than October 14, 1968.
22

23 **(c) Amendments to the Subdivision Ordinance .** This ordinance may be amended by
24 the Town Council following the procedure outlined in Sec. 19-4-9 of the Zoning
25 Ordinance.
26

27 **(d) Historical Interpretation.** This ordinance replaces the Subdivision Ordinance as
28 amended through 12-10-2003. Most of the prior ordinance provisions have not been
29 substantively changed and have been brought forward into this ordinance. When that
30 is the case, the interpretation by the town of the provision in the prior ordinance is
31 carried forward to this ordinance. [John Wall to revise as needed]

1
2 **Appendix A**

3 **Minor Subdivision Submission Requirements**

4 A. General submission parameters.

5 An application for a Minor Subdivision shall consist of fourteen (14) sets of plans drawn
6 to a scale of no larger than forty (40) feet to the inch and supporting materials. The size
7 of plan sheets submitted to the Planning Board shall be no larger than twenty-four (24) x
8 thirty-six (36) inches, but may be smaller with the permission of the Planning Board. A
9 digital copy of the complete application shall also be made available upon request.

10 B. List of Submission items.

11 The application for approval of a Minor Subdivision shall include all the following
12 information. Information that must be shown on a plan is in **bold type**.

- 13 1. Right, Title or Interest. Evidence of right, title or interest in the site of the proposed
14 subdivision.
- 15
- 16 2. Name of Subdivision/Applicant. **Proposed name of the subdivision, name and**
17 **address of record owner and applicant, names of adjoining property owners,**
18 **date of submission, north point, graphic map scale.**
- 19
- 20 3. Survey. **A standard boundary survey of the site, giving complete descriptive data**
21 **by bearings and distances, made and certified by a licensed land surveyor; a**
22 **copy of the deed for the property to be developed, as well as copies of any easements,**
23 **restrictions or covenants; a plan showing the number of the lot, dimensions of**
24 **area and building envelope of each proposed lot; existing easements; building**
25 **lines pertaining to the proposed subdivision and to the adjacent properties;**
26 **location map, showing the relative location of the proposed project in relation to**
27 **surrounding neighborhoods or areas of Town; sufficient data to determine**
28 **readily the location, bearing and length of every lot line, and boundary line and**
29 **to reproduce such lines upon the ground.** Where practical these should be tied to
30 reference points previously established;
- 31
- 32 4. Air and Water Pollution evaluation.
- 33
- 34 a. Topography. **Contour lines at intervals of two (2) feet or at such intervals as**
35 **the Planning Board may require, based on United States Geological Survey**
36 **datum, referenced to mean sea level;**
- 37
- 38 b. Surface drainage. **Surface drainage patterns including drainage channels and**
39 **watershed areas ;** the slope of the land and its effect on effluents; the
40 availability and condition of streams used for disposal of effluents; an evaluation
41 of applicable state and local health and water resource rules and regulations.
- 42
- 43 c. Soils. A soils report identifying **the soils boundaries and names in the proposed**
44 **development with the soils information superimposed upon the plot plan in**

1 **accordance with the USDA Soil Conservation Service National Cooperative**
2 **Soil Classification;**

- 3
- 4 d. Air. Description of any air emissions not normally included in residential
5 construction and use activities.
- 6
- 7
- 8 5. Potable Water. Confirmation of a clean and adequate supply of water to serve the
9 subdivision; **the location and size of any existing and proposed water mains on**
10 **the property and adjacent water lines that will provide water supply for the**
11 **property to be subdivided, as well as details showing connections to water**
12 **systems; nearest hydrant; Where public water is not to be provided, an**
13 **alternative means of a clean and adequate water supply shall be shown.**
- 14
- 15 6. Erosion. A soil erosion and sediment control plan prepared and certified by a
16 professional geologist or professional engineer.
- 17
- 18
- 19 7. Traffic. **Locations, widths and names of existing, filed or proposed roads, cross-**
20 **sections of the proposed grading for roadways, sidewalks, etc. including width,**
21 **type of pavement, elevations and grades, preliminary designs of any bridges or**
22 **culverts which may be required, designed to comply with the Road Design and**
23 **Construction Standards, Sec. 16-3-2;** a traffic study evaluating the capacity of
24 adjacent roads to safely accommodate the anticipated traffic generated by the
25 proposed subdivision, including an assessment of the likelihood of cut-through traffic,
26 efforts to provide for road connectivity, and applicability of the Maine Department of
27 Transportation regulations.
- 28
- 29 8. Sewage Disposal. **All on site public or shared sewage facilities;** A completed HHE
30 200 form or other subsurface wastewater design for every lot not served by public
31 sewer; **all designs, specifications and details for a clustered private or public**
32 **sewer system.**
- 33
- 34 9. Solid Waste Disposal. Demonstration of adequate capacity for disposal of
35 construction and solid waste to be generated by the subdivision.
- 36
- 37 10. Aesthetic, cultural and natural information. **Location of scenic, unique natural,**
38 **farmland, parkland, historic, and significant wildlife habitat areas located on or**
39 **adjacent to the proposed subdivision,** as well as supporting documentation.
- 40
- 41 11. Local regulations. **The boundaries and designations of zoning districts; applicable**
42 **space standard and setback provisions, and evaluation of the proposed**
43 **subdivision's compliance with applicable provisions such as Open Space Zoning**
44 **(Sec. 19-7-2).**
- 45

- 1 12. Financial and Technical Capability. Statement of Technical and Financial Capability,
2 including a list of the applicant’s development consultants, a description of all prior
3 development projects, and a letter of firm financial commitment from a bank or other
4 source of financing. In the case where the applicant asserts that public disclosure of
5 confidential financial information may prove detrimental to the applicant or the
6 project, the applicant may substitute a recommendation from the Town Manager that
7 the applicant has adequate financial capability to complete the project.
8
- 9 13. Surface Waters. **Location of any portion of the subdivision in the Shoreland**
10 **Zone; identification of the normal high water line;** assessment of how water
11 quality will be impacted by anticipated discharge from the subdivision.
12
- 13 14. Ground Water. An assessment of how the proposed subdivision will impact
14 groundwater resources.
15
- 16 15. Floodplain. **Location of any portion of the subdivision in the floodplain;**
17 assessment of how construction in the floodplain will comply with the Floodplain
18 Ordinance, Sec. 6-6.
19
- 20 16. Wetlands. **The boundaries of all wetlands in accordance with the Zoning**
21 **Ordinance;** an assessment of how any alterations of wetlands will comply with local
22 wetland regulations, Sec. 19-7-9.
23
- 24 17. Stormwater/Phosphorus. **A surface drainage plan or stormwater management plan,**
25 **with profiles and cross sections drawn by a professional engineer, registered in**
26 **the State of Maine, showing preliminary design of all facilities and conveyances**
27 **necessary to meet the stormwater management standards as set forth in this**
28 **ordinance.** Where the subdivision includes or abuts Great Pond, an assessment of
29 phosphorus loading amounts and impacts on Great Pond.
30
- 31 18. Liquidation Harvesting. **Identification of any portion of the subdivision where**
32 **timber has been harvested in violation of Title 12, section 8869, subsection 14.**
33
- 34 19. Landscaping. **An inventory of existing vegetation to be preserved;** methods of
35 preserving vegetation to be used during construction; **a landscaping plan including**
36 **planting locations, plant types, quantities and size and time of planting; fencing**
37 **location, type and material and size.**
38
- 39 20. Open Space. **Designation on the plan of land to be permanently protected as open**
40 **space; calculation of open space provided to meet the Open Space Impact Fee**
41 **(Sec. 16-3-1(t)); location of easements;** fee interest or easement deeds of open space
42 to be conveyed to the town or otherwise conserved;
43
- 44 21. Utilities. Evidence of the capacity to provide electrical and telephone facilities.
45
- 46 22. Phasing. **A phasing plan showing the boundaries and name of each phase.**

1
2
3
4
5
6
7

23. Related information. Any other data as determined by the Planning Board to ascertain compliance with this Ordinance.

1
2
3
4
5
6
7
8
9
10
11
12
13
14
15
16
17
18
19
20
21
22
23
24
25
26
27
28
29
30
31
32
33
34
35
36
37
38
39
40
41

Appendix B
Major Subdivision Submission Requirements
Preliminary Review

A. General submission parameters

An application for preliminary review of a Major Subdivision shall consist of fourteen (14) sets of plans drawn to a scale of no larger than forty (40) feet to the inch and supporting materials; The size of the plan sheets submitted to the Planning Board shall be no larger than twenty-four (24) x thirty-six (36) inches. (Revised eff. 12/10/03) A digital copy of the complete application shall also be made available upon request.

B. List of submission items.

The application for preliminary approval of a major subdivision shall include all the following information. Information that must be shown on a plan is in **bold type**.

1. Right, Title or Interest. Evidence of right, title or interest in the site of the proposed subdivision.
2. Name of Subdivision/Applicant. **Proposed subdivision name ; name and address of record owner and applicant; names of adjoining property owners; date of plan submission, north point and graphic map scale.**
3. Survey. **A standard boundary survey of the site giving complete descriptive data by bearings and distances, made and certified by a licensed land surveyor; a copy of the deed for the property to be developed, as well as copies of any easements, restrictions or covenants; a plan showing the number of the lot, conceptual dimensions of area and building envelope of each proposed lot sufficient to demonstrate minimum compliance with zoning requirements; existing easements; building lines pertaining to the proposed subdivision and to the adjacent properties; location map, showing the relative location of the proposed project in relation to surrounding neighborhoods or areas of Town; sufficient data to determine readily the location, bearing and length of every lot line and boundary line and to reproduce such lines upon the ground;**
4. Air and Water Pollution Evaluation.
 - a. Topography. **Contour lines at intervals of two (2) feet or at such intervals as the Planning Board may require, based on United States Geological Survey datum and referred to mean sea level;**
 - b. Surface drainage. **Surface drainage patterns including drainage channels and watershed areas;** the slope of the land and its effect on effluents; the availability

- 1 and condition of streams used for disposal of effluents; an evaluation of
2 applicable state and local health and water resource rules and regulations;
3
- 4 c. **Soils.** **A soils report identifying the soils boundaries and names in the**
5 **proposed development with the soils information superimposed upon the plot**
6 **plan in accordance with the USDA Soil Conservation Service National**
7 **Cooperative Soil Classification.**
8
- 9 d. Air. Description of any air emissions not normally included in residential
10 construction and use activities.
11
- 12 5. Potable Water. Confirmation of a clean and adequate supply of water to serve the
13 subdivision; **the location and size of any existing or proposed water mains on the**
14 **property and adjacent water lines that will provide water supply for the**
15 **property to be subdivided, as well as proposed connections to water systems;**
16 **nearest hydrant; where public water is not to be provided, an alternative means**
17 **of a clean and adequate supply shall be shown.**
18
- 19 6. Erosion. A soil erosion and sediment control plan shall be prepared and certified by a
20 professional geologist or professional engineer.
21
- 22 7. Traffic. **Location, widths and names of existing, filed and proposed roads;** a
23 traffic study evaluating the capacity of adjacent roads to safely accommodate the
24 anticipated traffic generated by the proposed subdivision, including an assessment of
25 the likelihood of cut-through traffic, efforts to provide for road connectivity, and
26 applicability of the Maine Department of Transportation Regulations;
27
- 28 8. Sewage Disposal. **All on site public or shared sewage facilities;** a completed HHE
29 200 form or other subsurface wastewater design for every lot not served by public
30 sewer.
31
- 32 9. Solid Waste Disposal. Demonstration of adequate capacity for disposal of
33 construction and solid waste to be generated by the subdivision.
34
- 35 10. Aesthetic, cultural and natural information. **Location of scenic, unique natural,**
36 **farmland, parkland, historic and significant wildlife habitat areas located on or**
37 **adjacent to the proposed subdivision,** as well as supporting documentation.
38
- 39 11. Local regulations. **The boundaries and designations of zoning districts; applicable**
40 **space standard and setback provisions of the Zoning Ordinance, and evaluation**
41 **of the proposed subdivision's compliance with applicable provisions such as**
42 **Open Space Zoning (Sec. 19-7-2).**
43
- 44 12. Financial and Technical Capability. Statement of Technical and Financial Capability,
45 including a list of the applicant's development consultants, a description of all prior
46 development projects, and a letter of firm financial commitment from a bank or other

1 source of financing. In the case where the applicant asserts that public disclosure of
2 confidential financial information may prove detrimental to the applicant or the
3 project, the applicant may substitute a recommendation from the Town Manager that
4 the applicant has adequate financial capability to complete the project.

- 5
- 6 13. Surface Waters. **Location of any portion of the subdivision in the Shoreland**
7 **Zoning; identification of the normal high water line**; assessment of how water
8 quality will be impacted by anticipated discharge from the subdivision.
9
- 10 14. Ground Water. As assessment of how the proposed subdivision will impact
11 groundwater resources.
12
- 13 15. Floodplain. **Location of any portion of the subdivision in the floodplain**;
14 assessment of how construction in the floodplain will comply with the Floodplain
15 Ordinance, Sec. 6-6.
16
- 17 16. Wetlands. **The boundaries of all wetlands in accordance with the Zoning**
18 **Ordinance**; an assessment of how any alterations of wetlands will comply with local
19 wetland regulations, Sec. 19-7-9.
20
- 21 17. Stormwater/Phosporus. A conceptual surface drainage plan or stormwater
22 management plan, , showing preliminary design of all facilities and conveyances
23 necessary to meet the stormwater management standards as set forth in this
24 Ordinance. Where the subdivision includes or abuts Great Pond, an assessment of
25 phosphorus loading amounts and impacts on Great Pond.
26
- 27 18. Liquidation Harvesting. **Identification of any portion of the subdivision where**
28 **timber has been harvested in violation of Title 12, section 8869, subsection 14**.
29
- 30 19. Landscaping. **An inventory of existing vegetation to be preserved**; methods of
31 preserving vegetation to be used during construction; **a conceptual landscaping**
32 **plan**.
33
- 34 20. Open Space. **Designation on the plan of the land to be permanently protected as**
35 **open space**; **calculation of the open space provided to meet the Open Space**
36 **Impact Fee (Sec. 16-3-1(t))**; **location of easements**; fee interest or easement deeds
37 of open space to be conveyed to the town or otherwise conversed.
38
- 39 21. Utilities. Evidence of the capacity to provide electrical and telephone facilities.
40
- 41 22. Phasing. A concept phasing plan, if the project will be phased.
42
- 43 23. Related Information. Any other data as determined by the Planning Board to ascertain
44 compliance with this ordinance.
45

- 1 24. Community Impact Analysis. The Planning Board may require the applicant to
2 conduct a community impact analysis which will consist of the following
3 demographic features.
4
- 5 a. Demographic Description. The analysis must identify the demographic market the
6 project intends to serve, including:
7 (1) type of family;
8 (2) average family size;
9 (3) number and ages of children; and
10 (4) anticipated time period to fill all units or lots.

11
12 Associated data, such as anticipated income levels, type of employment, and
13 projected housing costs may also be presented to support projections associated with
14 the above demographic description.

- 15
- 16 b. Community Impact Analysis. Utilizing the above demographic data, the applicant
17 shall conduct analyses of the following:
18 (1) Estimated impact of traffic systems, including the impact of projects trips on
19 flow characteristics and the impact of traffic on the immediate, existing road
20 structures;
21 (2) Estimated impact on the school system;
22 (3) Estimated impact on public safety providers;
23 (4) Estimated impact on the public works department, including solid waste
24 disposal;
25 (5) Estimated impact on existing storm water management systems including
26 flow and water quality;
27 (6) Estimated impact on the recreation resources and provision of methods to
28 meet proposed needs;
29 (7) Estimated impact on wildlife habitat areas;
30 (8) Impact on the stated goals and objectives of the Comprehensive Plan; and
31 (9) Any other study deemed appropriate by the Planning Board.

32
33 Once these analyses have been completed, the applicant shall present this information
34 and impact assessments to the Planning Board for its review and comment.

35 **Final Review**

- 36 A. General submission parameters. Same as for Preliminary Review.
37 B. List of submission items
- 38 1. Preliminary Approval. All information required to be shown on the preliminary plans,
39 with all amendments required by the Planning Board and other reviewing agencies
40 and those suggested by the Planning Board and adopted by the applicant, and further
41 augmented as follows:

- 1 2. **Survey. Final plan showing the number of the lot, final calculations of lot area,**
2 **property line dimensions and building envelope for each proposed lot.**
- 3 3. **Potable Water. The preliminary plan approved by the Planning Board for water**
4 **supply supplemented to include final design, details and specifications of**
5 **installation and connection to existing water mains.**
6
- 7 4. **Traffic. The preliminary plan approved by the Planning Board for road access**
8 **and traffic supplemented to include final design, details and specifications of**
9 **proposed roads, driveways as needed, and connections to existing roads.**
10
- 11 5. **Sewage Disposal. The preliminary plan approved by the Planning Board for**
12 **public or private cluster sewage system supplemented to include final design,**
13 **details, and specifications of proposed sanitary waste infrastructure and**
14 **connections to public sewer lines.**
- 15 6. **Local regulations. The preliminary plan approved by the Planning Board**
16 **updated to reflect any changes to how the project complies with local**
17 **regulations.**
- 18 7. **Financial Capability. Performance guarantee estimate with detail of unit cost and**
19 **quantity for the subdivision, segmented into phases if the proposed subdivision will**
20 **be phased; draft performance guarantee document including issuing agent.**
- 21 8. **Stormwater/Erosion. The preliminary plan approved by the Planning Board for**
22 **stormwater management and erosion control supplemented to include final**
23 **design, details, and specifications of the proposed stormwater infrastructure and**
24 **any connections to existing stormwater facilities.**
25
- 26 9. **Landscaping. The preliminary plan approved by the Planning Board for**
27 **landscaping supplemented to include final design, details and specifications**
28 **including but not limited to a detailed planting plan showing vegetation to be**
29 **preserved, preservation plan, new planting locations, planting types, quantities**
30 **and size at time of planting, fencing location, type, size and materials.**
- 31 10. **Open Space. The preliminary plan approved by the Planning Board for open space**
32 **preservation supplemented by draft written conservation restrictions, easement deeds,**
33 **survey descriptions, and any other documentation.**
34
- 35 11. **State and Federal permits. Written evidence of the issuance of all permits, licenses**
36 **and approvals required for the subdivision from any federal, state or other local**
37 **agency;**
38
- 39 12. **Conditional Municipal Approval. Written evidence of (i) the offer and conditional**
40 **municipal approval by the Town Council of all roads, sewer lines, drainage**
41 **easements, proposed public open space, recreation land, and other such common**
42 **areas and facilities proposed to be dedicated to the Town; or (ii) satisfactory**
43 **agreements or other documents showing the manner in which private roads, sewer**
44 **lines and systems, drainage ways, open space, recreation land, and other such**

1 common areas and facilities are to be maintained. Written agreements of a dedication
2 to a third party other than the Town must also be submitted and deemed satisfactory
3 by the Planning Board.
4

5 13. Phasing Plan. **If the subdivision will be constructed in phases, the phasing plan**
6 **shall show the entire subdivision and every part of the subdivision shall be**
7 **assigned to a phase.** The plan shall also identify the sequence of construction of
8 phases and **show how utilities, emergency vehicle access, turnaround space and**
9 **any other element of the development that will be impacted by phasing will be**
10 **accommodated for each phase.**

11
12 13. Recording Plat. **A Subdivision Plat suitable for recording which includes a**
13 **prominent notation that there shall be no sale of lots, nor issuance of building**
14 **permits, nor site work commenced until the required performance guarantee**
15 **has been approved in accordance with Sec. 16-2-6(c).**

Appendix C Road Tree List

The following trees are recommended for planting to meet the road tree requirements. Alternative species may also be acceptable upon approval of the Tree Warden, unless specified by the Planning Board. The list includes the scientific and common tree name, minimum required caliper at the time of planting, expected height at maturity and comments. The comments refer to tree characteristics of water and salt tolerance.

| Scientific | Common | Size | Height | Comments* |
|--------------------------|----------------------|-------------|---------------|------------------|
| Acer campestre | Hedge Maple | 2" | 45' | D,M |
| Acer saccharum | Sugar Maple | 2" | 80' | WD |
| Acer pseudoplatanus | Planetree maple | 2" | 60' | WD,H |
| Acer rubrum | Red Maple Cultivars | 2" | 60' | W,M |
| Betula alleghaniensis | Yellow Birch | 2" | 50' | W |
| Betula nigra | Heritage River Birch | 2" | 60' | W |
| Carpinus caroliniana | American Hornbeam | 2" | 30' | W |
| Cercidiphyllum japonicum | Katsura | 2" | 60' | W |
| Chionanthus virginicus | Fringetree | 2" | 30' | W |
| Cladrastus kentuckea | Yellowwood | 2" | 60' | W |
| Corylus colurna | Turkish Filbert | 2" | 50' | D |
| Crateagus spp. | Hawthorne | 2" | 30' | D |
| Ginkgo biloba | Maidenhair Tree | 2" | 60' | D,M |
| | Cultivars | | | |
| Maackia amurensis | Maackia | 2" | 40' | W |
| Nyssa sylvatica | Tupelo | 2" | 60' | W |
| Platanus acerfolia | London Plane | 2" | 75' | W |
| Quercus bicolor | Swamp White oak | 2" | 55' | W |
| Quercus rubra | Red Oak | 2" | 75' | D |
| Sorbus alnifolia | Korean Mountain Ash | 2" | 35' | D,M |
| Syringa reticulate | Japanese Tree Lilac | 2" | 30' | D,M |
| Zelkova serrata | Zelkova | 2" | 50' | W |

* W= Wet, D=Dry, WD=Well Drained, M=Moderate Salt Tolerance and H= High Salt Tolerance

All trees shall be planted in accordance with the Planting Specifications of the Cape Elizabeth Comprehensive Street Tree Plan.

1
2
4
6

Appendix D Turnaround Specifications Placeholder

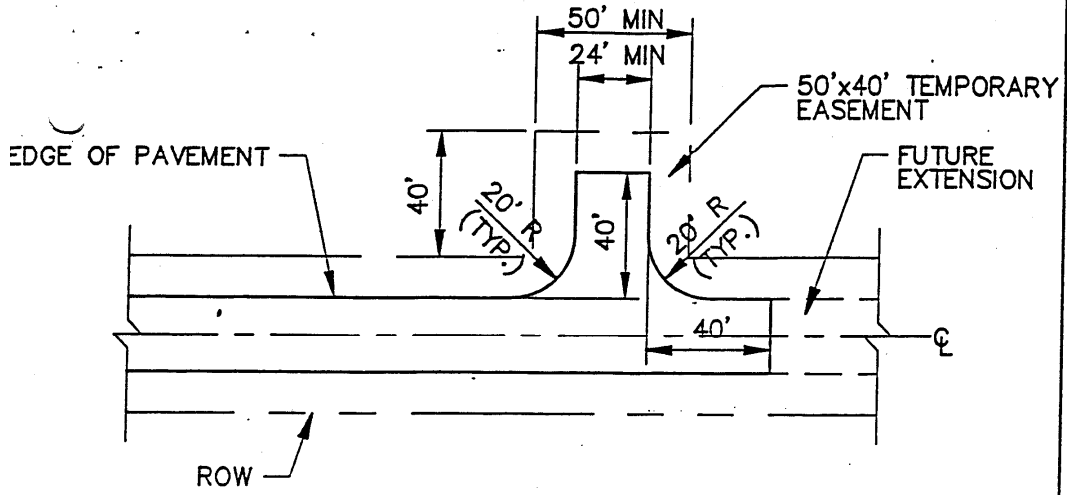

ALTERNATE 1

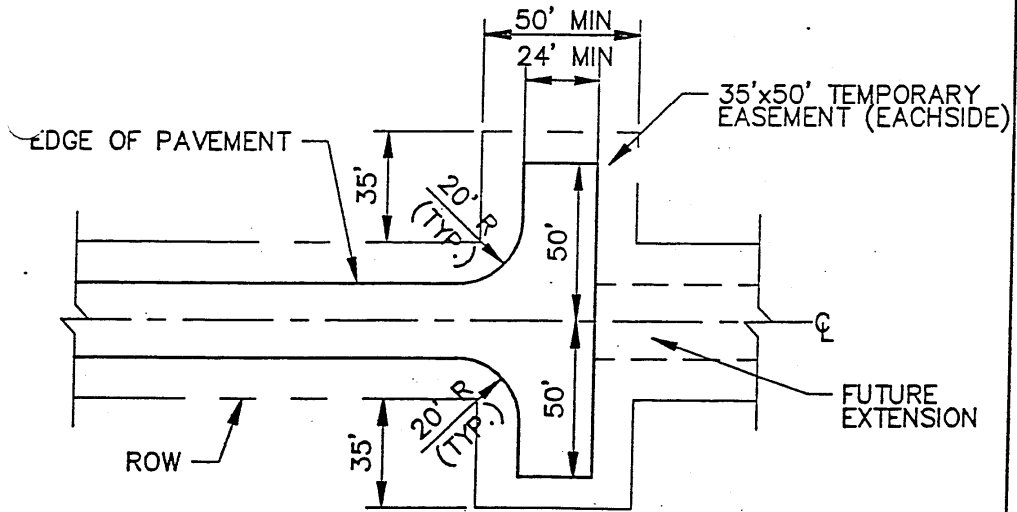

ALTERNATE 2

MINIMUM DIMENSIONS FOR TURN-AROUNDS

NOT TO SCALE

1
2
3
4

Appendix E Road Profiles

Placeholder

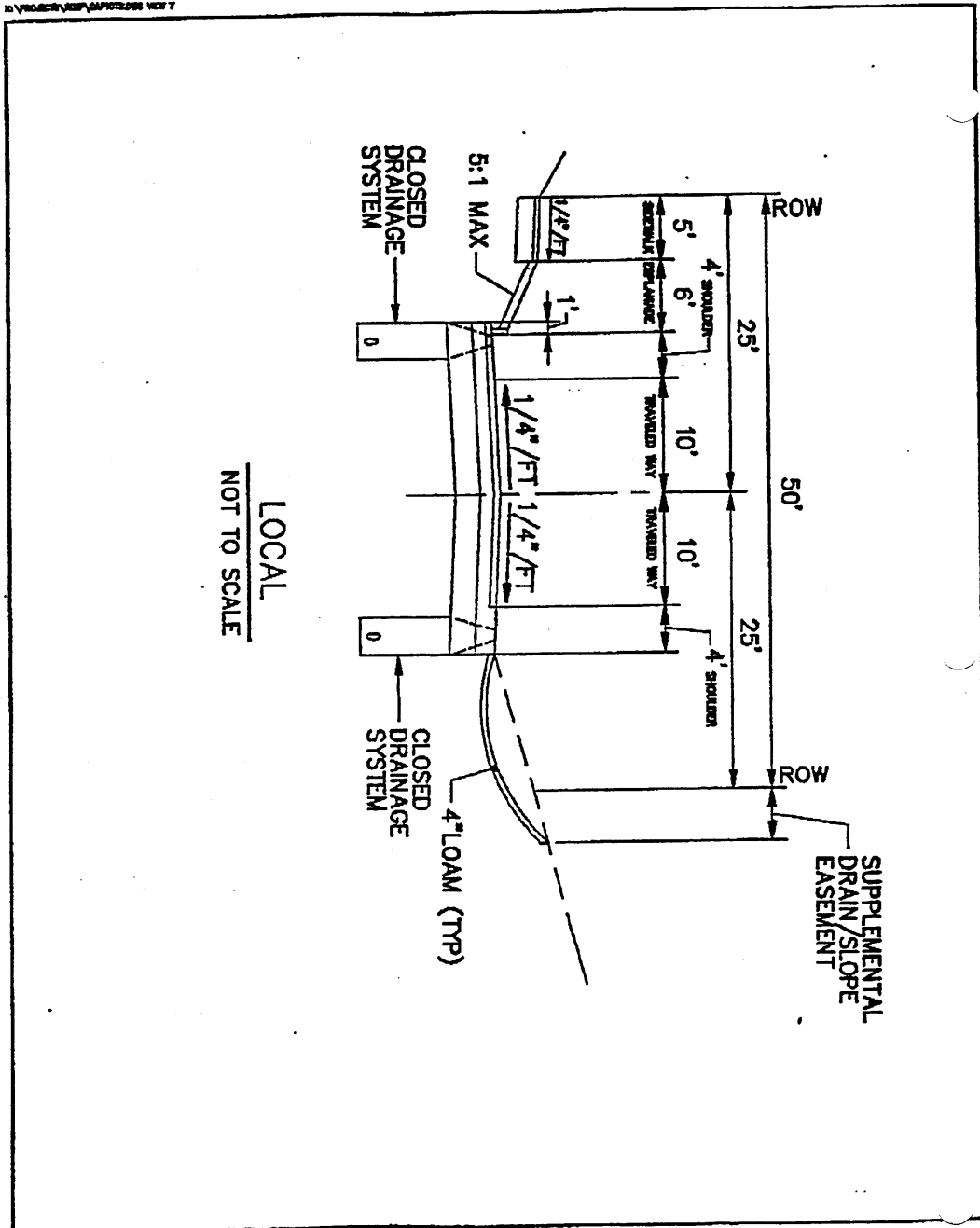

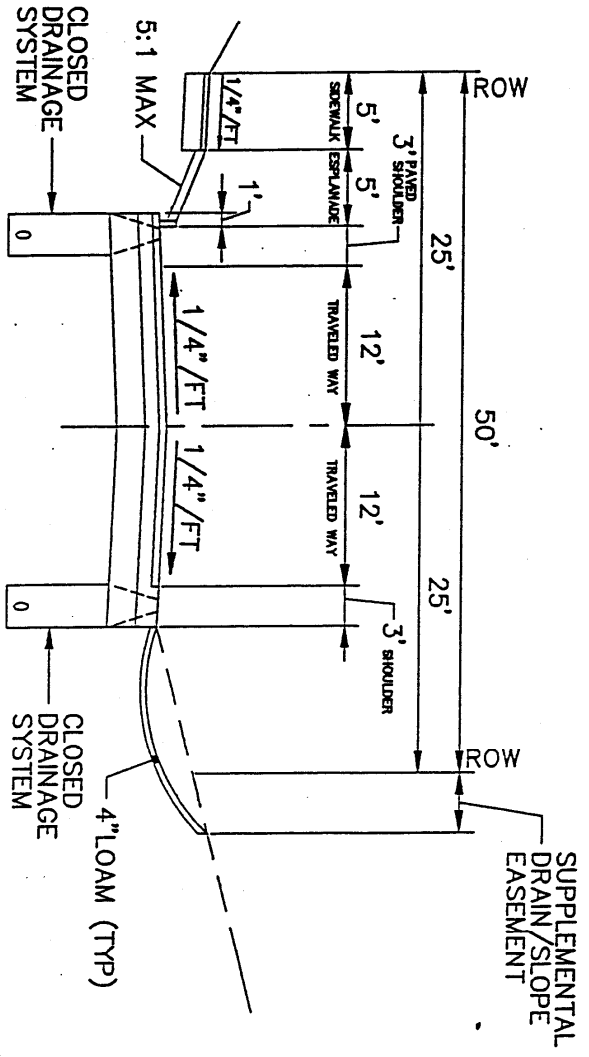

FEEDER
 NOT TO SCALE